

CS20

EULER : A GENERALIZATION OF ALGOL,  
AND ITS FORMAL DEFINITION

BY

**NIKLAUS WIRTH** and HELMUT WEBER

TECHNICAL REPORT **CS20**

APRIL 27, 1965

COMPUTER SCIENCE DEPARTMENT  
School of Humanities and Sciences  
STANFORD UNIVERSITY





ERRATA et ADDENDA

- p.4, l4 : replace "systemizing" by "systematizing" .  
l21: replace "in [8]" by "here" .
- p.5, l6 : "standard" should read "fixed" .
- p.6, l14: underline "productive" .  
l16: underline "reductive" .
- p.10, l21: replace curly braces { } by parentheses ( ) .
- p.11, 110: dito  
l11: dito  
l18: add the following sentence:  
(as an alternative notation for cx we will use x.)
- p.13, l3 : replace {,} by (,) respectively .
- p-15, l11: after "U → x" insert "where" .  
l14: insert a space after the first z; ...z (y → z)....  
l17: dito
- p.16, l2 : underline the word "sentence" .  
l4 : underline "simple phrase structure language" .
- p.26, l9 : the third symbol to the right of the vertical line should be  
"'" instead of "'".
- p.37, l17: change "enumerate" into "enumerate" .
- p.38, l31: underline the letter V .  
l34: (bottom line) dito.
- p.41 : the horizontal line should be between IDENT and DIGIT instead  
of between DIGIT and NUMBER.
- p-48, l23: "a[1]" instead of "a[i]" .



-

p.52,            122: "will" instead of "would" .

p.63, #4,       16 : add a semicolon (;) to the right.  
                   18 : dito, also underline label  
                   111: add a semicolon to the right.

p.64, #37,      12 : "P[V[j][2] ← k + 1" should be "P[V[j][2]] ← k + 1" .

p.65, #50       : "isn var" should be "isb var"

p.65, #57       : change the two occurrences of "isn" into "isu" .

p.67, #114      : change "blockhead" into "blokhead"

p.70,           16 : change the colon at the right into a semicolon.  
                   113: add the symbol "↑" underneath mod .

p-71,           112: "At i - i - 1" should be "A: i ← i - 1" .

p.72,           14 : change "string" into "symbol".  
                   129: add a semicolon at the right.

p.73,           114: dito

p-75,           14 : insert a semicolon in front of "x ← s[1]" .

p.77,           125: change "is a number" into "is not a number".

p-91,           122: "RESUTS" should read "RESULTS" .

p-981           117: change "13" at the left into "28".

p.110,          117: add to the right: "S[SP].ADR ← FP; COMMENT A NULL LIST;"



# EULER : A Generalization of ALGOL, and its Formal Definition\*

by

Niklaus Wirth and Helmut Weber

Abstract:

A method for defining programming languages is developed which introduces a rigorous relationship between structure and meaning. The structure of a language is defined by a phrase structure syntax, the meaning in terms of the effects which the execution of a sequence of interpretation rules exerts upon a fixed set of variables, called the Environment. There exists a one-to-one correspondence between syntactic rules and interpretation rules, and the sequence of executed interpretation rules is determined by the sequence of corresponding syntactic reductions which constitute a parse. The individual interpretation rules are explained in terms of an elementary and obvious algorithmic notation. A constructive method for evaluating a text is provided, and for certain decidable classes of languages their unambiguity is proven. As an example, a generalization of ALGOL is described in full detail to demonstrate that concepts like block-structure, procedures, parameters etc. can be defined **adequately** and precisely by this method.

---

\*/ This work was partially supported by the National Science Foundation (GP 4053) and the Computation Center of Stanford University.





It is the character of mathematics of modern times that through our language of signs and nomenclature we possess a tool whereby the most complicated arguments are reduced to a certain mechanism. Science has thereby gained infinitely, but in beauty and solidity, as the business is usually carried on, has lost so much. How often that tool is applied only mechanically, although the authorization for it in most cases implied certain silent hypotheses! I demand that in all use of calculation, in all uses of concepts, one is to remain always conscious of the original conditions.

Gauss

(in a letter to Schumacher, Sept. 1, 1850)



-

TABLE OF CONTENTS

I. Introduction and Summary. . . . . 1

II. An Elementary Notation for Algorithms . . . . . 9

III. Phrase Structure Programming Languages. . . . . 15

    A. Notation, Terminology, Basic Definitions. . . . . 15

    B. Precedence Phrase Structure Systems . . . . . 18

        1. The Parsing Algorithm for **Simple Precedence**  
            **Phrase Structure Languages**, , , , , . . . . . 18

        2. The Algorithm to Determine the  
            Precedence Relations. . . . . 21

        3. **Examples**. . . . . 24

        4. The Uniqueness of a Parse . . . . . 26

        5. Precedence Functions. . . . . 27

        6. Higher Order Precedence Syntax. . . . . 29

    C. An Example of a Simple Precedence , , ,  
        Phrase Structure Programming Language , . . . . 35

IV. EULER: An Extension and Generalization of ALGOL 60 . . 43

    A. An Informal Description of EULER. . . . . 43

        1. Variables and Constants . . . . . 43

        2. Expressions . . . . . 50

        3. Statements and Blocks . . . . . 53

        4. Declarations. . . . . 54

    B. The Formal Definition of EULER. . . . . 56

    C. Examples of Programs. . . . . 75

References. . . . . 81

Appendix I . . . . . 83

Appendix II . . . . . 92



-

## I. Introduction and Summary

When devising a new programming language, one inevitably becomes confronted with the question of how to define it. The necessity of a formal definition is twofold: the users of this language need to know its precise meaning, and also need to be assured that the automatic processing systems, i.e. the implementations of the language on computers, reflect this same meaning equally precisely. ALGOL 60 represented the first serious effort to give a formal definition of a programming language [1]. The structure of the language was defined in a formal and concise way (which, however, was not in all cases unambiguous), such that for every string of symbols it can be determined whether it belongs to the language ALGOL 60 or not. The meaning of the sentences, i.e. their effect on the computational process, was defined in terms of ordinary English with its unavoidable lack of precision. But probably the greater deficiency than certain known imprecise definitions was the incompleteness of the specifications. By this no reference is made to certain intentional omissions (like specification of real arithmetic), but to situations and constructs which simply were not anticipated and therefore not explained (e.g. dynamic own arrays or conflicts of names upon procedure calls). A method for defining a language should therefore be found which guarantees that no unintentional omissions may occur.

How should meaning be defined? It can only be explained in terms of another language which is already well understood. The method of formally deriving the meaning of one language from another makes sense, if and only if the latter is simpler in structure than the former. By a sequence of such derivations a language will ultimately be reached where it would not

be sensible to define it in terms of anything else. Recent efforts have been conducted with this principle in mind.

Böhm [3] and Landin [4][5] have chosen the h-calculus as the fundamental notation [6],[7], whose basic element is the function, i.e. a well-established concept. The motivation for representing a program in functional form is to avoid a commitment to a detailed sequence of basic steps representing the algorithm, and instead to define the meaning or effect of a program by the equivalence class of algorithms represented by the indicated function. Whether it is worth while to achieve such an abstract definition of meaning in the case of programming languages shall not be discussed here. The fact that a program consists basically of single steps remains, and it cannot even be hidden by a transliteration into a functional notation: the sequence is represented by the evaluations of nests of functions and their parameters. An unpleasant side-effect of this translation of ordinary programming languages into h-calculus is that simple computer concepts such as assignment and jumps transform into quite complicated constructs, this being in obvious conflict with the stated requirement that the fundamental notation should be simple.

Van Wijngaarden describes in [8] and [9] a more dynamic approach to the problem: the fundamental notation is governed by only half a dozen rules which are obvious. It is in fact so simple that it is far from being a useful programming notation whatsoever, but just capable enough to provide for the mechanism of accepting additional rules and thus expanding into any desirable programming system. This method of defining the meaning

(or, since the meaning is imperative: effect) of a language is clearly distinct from the method using functional notations, in that it explicitly makes use of algorithmic action, and thus guarantees that an evaluating algorithm exists for any sentence of the language. The essence of this algorithm consists of first scanning the ordered set of rules defining the structure of the language, and determining the applicable structural designations, i.e. performing an 'applicability scan', and then scanning the set of rules for evaluating the determined structural units, i.e. performing an 'evaluation scan'. The rules are such that they may invoke application of other rules or even themselves. The entire mechanism is highly recursive and the question remains, whether a basically subtle and intricate concept such as recursion should be used to explain other programming languages, including possibly very simple ones.

The methods described so far have in common that their basic set of fundamental semantic entities does not resemble the elementary operations performed by any computational device presently known. Since the chief aim of programming languages is their use as communication media with computers, it would seem only natural to use a basic set of semantic definitions closely reflecting the computer's elementary operators. The invaluable advantage of such an approach is that the language definition is itself a processing system and that implementations of the language on actual machines are merely adaptations to particular environmental conditions of the language definition itself. The question of correctness of an implementation will no longer be undecidable or controversial, but can be directly based on the correctness of the individual substitutions of the elementary semantic units by the elementary machine operations.

It has elsewhere been proposed (e.g. [10]) to let the processing systems themselves be the definition of the language. Considering the complexity of known compiler-systems this seems to be an unreasonable suggestion, but if it is understood as a call for systemizing such processing systems and representing them in a notation independent from any particular computer, then the suggestion appears in a different light.

The present paper reports on efforts undertaken in this direction. It seems obvious that the definition of the structure, i.e. the syntax, and the definition of the meaning should be interconnected, since structural orderings are merely an aid for understanding a sentence. In the presented proposal the analysis of a sentence proceeds in parallel with its evaluation: whenever a structural unit is discovered, a corresponding interpretation rule is found and obeyed. The syntactic aspects are defined by a Phrase Structure System (cf. [11], [12], [2]) which is augmented by the set of interpretation rules defining the semantic aspects. Such an augmented Phrase Structure Language is subsequently called a Phrase Structure Programming Language, implying that its meaning is strictly imperative and can thus be expressed in terms of a basic algorithmic notation whose constituents are, e.g., the fundamental operations of a computer.

Although in [8] the processes of syntactic analysis and semantic evaluation are more clearly separated, the analogies to the van Wijngaarden proposal are apparent. The parsing corresponds to the applicability scan, the execution of an interpretation rule to the evaluation scan. However, this proposal advocates the strict separation between the rules which define the language, i.e. its analysis and evaluation mechanisms, and the



rules produced by the particular program under evaluation, while the van Wijngaarden proposal does not distinguish between language definition and program. Whether the elimination of this distinction which enables-- and forces--the programmer to supply his own language defining rules, is desirable or not must be left unanswered here. The original aim of this contribution being the development of a proposal for a standard language, it would have been meaningless to eliminate it.

Chapter II contains the descriptions of an algorithmic notation considered intuitively obvious enough not to necessitate further explanation in terms of more primitive concepts. This notation will subsequently be used for the definition of algorithms and interpretation rules, thus playing a similar role for the semantic aspects as did BNF for the syntactic aspects of ALGOL 60. The function of this notation is twofold:

1. It serves to precisely describe the analysis and evaluation mechanisms,
- and 2. It serves to define the basic constituents of the higher level language. E.g., this basic notation contains the elementary operators for arithmetic, and therefore the specifications of the higher level language defer their definition to the basic algorithmic notation. It is in fact assumed that the definition of integer arithmetic is below the level of what a programming language designer is concerned with, while real arithmetic shall very intentionally not be defined at all in a language standard. The concepts which are missing in the basic notation and thus will have to be defined by the evaluation mechanisms are manifold: the sequencing of operations and operands in expressions, the storage allocation, the block structure, procedure structure, recursivity, value- and name-parameters, etc.

Chapter III starts out with a list of basic formal definitions leading to the terms 'Phrase Structure System' , 'Phrase Structure Programming Language' and 'Meaning' . The notation and terminology of [12] is adopted here as far as possible. The fact that the nature of meaning of a programming language is imperative, allows the meaning of a sentence to be explained in terms of the changes which are affected on a certain set of variables by obeying the sentence. This set of variables is called the Environment of the Programming Language. The definition of the meaning with the aid of the structure, and the definition of the evaluation algorithm in terms of structural analysis of a sentence demand that emphasis be put on the development of a constructive algorithm for a syntactic analysis. Chapter III is mainly devoted to this topic. It could have been entirely avoided, had a reductive instead of a productive definition of the syntax been chosen. By a productive syntactic definition is meant a set of rules illustrating the various constructs which can be generated by a given syntactic entity. By a reductive syntactic definition is meant a set of rules directly illustrating the reductions which apply to a given sentence. A reductive syntax therefore directly describes the analyser, and recently some compilers have been constructed directly relying on a reductive syntactic description of the language. [13]. A language definition, however, is not primarily directed toward the reader (human or artificial), but toward the writer or creative user. His aim is to construct sentences to express certain concepts or ideas. The productive definition allows him to derive directly structural entities which conform to his concepts. In short, his use of the language is primarily synthetic and not analytic in nature. The reader then must apply an analytic process, which

in turn one should be able to specify given the productive syntactic definitions. One might call this a transformation of a productive into a reductive form, a synthetic into an analytic form.

The transformation method derived subsequently is largely based on earlier work by R. W. Floyd described in [14]. The grammars to which this transformation applies are called Precedence Grammars. The term 'Precedence Syntax' is, however, redefined, because the class of precedence grammars described in [14] was considered to be too restrictive, and even unnecessarily so. In particular, there is no need to define the class of precedence grammars as a subclass of the 'Operator grammars'. Several classes of precedence grammars are defined here, the order of a precedence grammar being determined by the amount of context the analysis has to recognize and memorize in order to make decisions. This classification relates to the definition of 'Structural Connectedness' described in [15], and provides a means to effectively determine the amount of connectedness for a given grammar.

Also in Chapter III, an algorithm is described which decides whether a given grammar is a precedence grammar, and if so, performs the desired transformation into data representing the reductive form of the grammar.

A proof is then provided of the unambiguity of precedence grammars, in the sense that the sequence of syntactic reductions applied to a sentence is unique for every sentence in the language. Because the sequence of interpretation rules to be obeyed is determined by the sequence of syntactic reductions, this uniqueness also guarantees the unambiguity of meaning, a crucial property for a programming language. Furthermore, the fact that all possible reductions are described exhaustively by the syntax,

and that to every syntactic rule there exists a corresponding interpretation (semantic) rule, guarantees that the definition of meaning is exhaustive. In other words, every sentence has one and only one meaning, which is well defined, if the sentence belongs to the language. Chapter III ends with a short example: The formal definition of a simple programming language containing expressions, assignment statements, declarations and block-structure.

A formal definition of an extension and generalization of ALGOL 60 is presented in Chapter IV. It will demonstrate that the described methods are powerful enough to define adequately and concisely all features of a programming language of the scope of ALGOL 60. This generalization is a further development of earlier work presented in [16].

## II. An Elementary Notation for Algorithms.

This notation will in subsequent chapters be used as basis for the definitions of the meaning of more complicated programming languages.

A program is a sequence of imperative statements. In the following paragraphs the forms of a statement written in this elementary notation are defined and rules are given which explain its meaning. There exist two different kinds of statements:

- A. the Assignment Statement, and
- B. the Branching Statement.

The Assignment Statement serves to assign a new value to a variable whose old value is thereby lost. The successor of an Assignment Statement is the next statement in the sequence. The Branching Statement serves to designate a successor explicitly. Statements may for this purpose be labelled.

### A. The Assignment Statement

The (direct) Assignment Statement is of the form

$$v \leftarrow E .$$

$v$  stands for a variable and  $E$  for an expression. The meaning of this statement is that the current value of  $v$  is to be replaced by the current value of  $E$ .

An expression is a construct of either one of the following forms:

$$x , o x , x \Theta y , r$$

where  $x, y$ , stand for either variables, literals or lists,  $o$  stands for a unary operator,  $\Theta$  stands for a binary operator and  $r$  stands for a reference. The value of an expression involving an operator is obtained by applying the operator to the current value(s) of the operand(s).

A reference is written as @**v**, where v is the referenced variable.

The indirect Assignment Statement is written as

$$\mathbf{v} \leftarrow \mathbf{E}$$

and is meant to assign the current value of the expression E to the variable, whose reference is currently assigned to the variable v .

### 1. Literals

A literal is an entity characterized by the property that its value is always the literal itself. There may exist several kinds of literals, e.g. '

Numbers

Logical constants (Boolean)

**Symbols**

Furthermore there exists the literal  $\Omega$  with the meaning "undefined".

Numeric constants shall be denoted in standard decimal form. The logical constants are true and false\*

A symbol or character is denoted by the symbol itself enclosed in quote marks (''). A list of **symbols** is usually called a **string**. Other types of literals may arbitrarily be introduced.

### 2. Lists

A list is an entity denoted by'

$$\{\mathbf{E}, \mathbf{F}, \dots, \mathbf{G}\}$$

whose value is the ordered set of the current values of the expressions E, F, . . . , G, called the elements of the list. A list can have any **number** of elements (including 0), and the elements are numbered with the natural numbers starting with 1 .

---

\* the underlined (boldface) letters have to be understood as one single symbol.

### 3. Variables

A variable is an entity uniquely identified within a program by a name to which a value can be assigned (and reassigned) during the execution of a program. Before the first assignment to a variable, its value shall be  $\Omega$ .

If the value of a variable consists of a sequence of elements, any one element may be designated by the variable name and a subscript, and thus is called a subscripted variable. The subscript is an expression, whose current value is the ordinal number of the element to be designated. Thus, after  $a \leftarrow \{1, 2, \{3, 4, 5\}, 6\}$ ,  $a[1]$  designates the element "1",  $a[3]$  designates the element  $\{3, 4, 5\}$ , and therefore  $a[3][2]$  designates the second element of  $a[3]$ , i.e. "4". The notation  $a_i$  shall be understood equivalent to  $a[i]$ ,  $a_{i,j}$  equivalent to  $a[i][j]$  etc.

### 4. Unary Operators

Examples of unary operators are:

$- x$  , yields the negative of  $x$

$\underline{c} x$  , yields the value of the variable whose reference is currently assigned to  $x$

$\underline{abs} x$  , yields the absolute value of  $x$

$\underline{integer} x$  , yields  $x$  rounded to the nearest integer

$\underline{tail} x$  , yields the list  $x$  with its first element deleted;

$\underline{isli} x$  , yields true, if  $x$  is a list, false otherwise

A further set of unary operators is the set of typetest operators which determine whether the current value of a variable is a member of a certain set of literals. The resulting value is true, if the test is affirmative, false otherwise.

Examples:

isn x, current value of x is a number

isb x, .....is a logical (Boolean) constant

isu x, .....is  $\Omega$  (undefined)

isy x, . . . . .is a symbol

A further set of unary operators is the set of conversion operators which produce values of a certain type from a value of another type:

Examples:

real x yields the number corresponding to the logical value x;

logical x inverse of real (true  $\leftrightarrow$  1, false  $\leftrightarrow$  0 shall be assumed);

Conversion operators between numbers and symbols shall not be defined here, although their existence is assumed, because the notation does not define the set of symbols which may possibly be used.

## 5. Binary Operators

Examples of binary operators are:

+ -  $\times$  designating addition, subtraction and multiplication in the usual sense. The accuracy of the result in the case of the operands being non-integral numbers is not defined.

/ denoting division in the usual sense. The accuracy of the result is not defined here. In case of the denominator being 0, the result is  $\Omega$ .

$\div$  denoting division between the rounded operands with the result being truncated to its integral value.



mod yields the remainder of the division denoted by  $\div$  .

& yields the concatenation of two lists, i.e.

$$\{x\} \& \{y\} = \{x,y\}$$

= yields true, if the two scalar operands are equal, false otherwise.

↑ denoting exponentiation, i.e.  $x \uparrow y$  stands for  $x^y$  .

The classes of unary and binary operators listed here may be extended and new types of literals may be introduced along with corresponding typetest and conversion operators.

## B. The Branching Statement

There are Simple and Conditional Branching Statements.

### 1. The Simple Branching Statement

It is of the form

$$\text{goto } l$$

where  $l$  stands for a label. The meaning is that the successor of this statement is the statement with the label  $l$  . Labelling of a statement is achieved by preceding it with the label and a colon (:). The label is a unique name (within a program) and designates exactly one statement of the program.

### 2. The Conditional Branching Statement

It is of the form

$$\text{if } E \text{ then goto } l$$

where  $l$  is a label uniquely defined in the program and  $E$  is an expression. The meaning is to select as the successor to the

Branching Statement the statement with the label  $l$ , if the current value of  $E$  is true, or the next statement in the sequence, if it is false. For notational convenience a statement of the form

if  $\neg E$  then goto  $l$  ( $\neg$  = not)

shall be admitted and understood in the obvious sense.

\*\*\*\*\*

Notational standards shall not be fixed here. Thus the sequence of statements can be established by separating statements by delimiters, or by beginning a new line for every statement. The Branching Statement and the labelling of statements may be replaced by explicit arrows, thus yielding block diagrams or flow-charts.

### III. Phrase Structure Programming Languages!

#### A. Notation, Terminology, Basic Definitions

Let  $\mathcal{V}$  be a given set: the vocabulary. Elements of  $\mathcal{V}$  are called symbols and will be denoted by capital Latin letters, S, T, U etc. Finite sequences of symbols -- including the empty sequence ( $\Lambda$ ) -- are called strings and will be denoted by small Latin letters -- x, y, z, etc. The set of all strings over  $\mathcal{V}$  is denoted by  $\mathcal{V}^*$ . Clearly  $\mathcal{V} \subseteq \mathcal{V}^*$ .

A simple phrase structure system is an ordered pair  $(\mathcal{V}, \Phi)$ , where  $\mathcal{V}$  is a vocabulary and  $\Phi$  is a finite set of syntactic rules  $\phi$  of the form

$$U \rightarrow x \quad (U \in \mathcal{V}, x \in \mathcal{V}^*).$$

For  $\phi = U \rightarrow x$ , U is called the left part and x the right part of  $\phi$ .

y directly produces z ( $y \dot{\rightarrow} z$ ) and conversely z directly reduces into y, if and only if there exist strings u, v such that  $y = uUv$  and  $z = uxv$ , and the rule  $U \rightarrow x$  is an element of  $\Phi$ .

y produces z ( $y \xrightarrow{*} z$ ) and conversely z reduces into y, if and only if there exist a sequence of strings  $x_0, \dots, x_n$ , such that  $y = x_0$ ,  $x_n = z$ , and  $x_{i-1} \dot{\rightarrow} x_i$  ( $i = 1, \dots, n; n > 1$ ).

A simple phrase structure syntax is an ordered quadruple  $\mathcal{G} = (\mathcal{V}, \Phi, \mathcal{B}, A)$ , where  $\mathcal{V}$  and  $\Phi$  form a phrase structure system;  $\mathcal{B}$  is the subset of  $\mathcal{V}$  such that none of the elements of  $\mathcal{B}$  (called basic symbols) occurs as the left part of any rule of  $\Phi$ , while all elements of  $\mathcal{V} - \mathcal{B}$  occur as left part of at least one rule; A is the symbol which occurs in no right part of any rule of  $\Phi$ .

The letter  $U$  shall always denote some symbol  $U \in \mathcal{V} - \mathcal{B}$ .

$x$  is a sentence of  $\mathcal{L}$ , if  $x \in \mathcal{V}^*$  (i.e.  $x$  is a string of basic symbols) and  $A \xrightarrow{*} x$ .

A simple phrase structure language  $\mathcal{L}$  is the set of all strings  $x$  which can be produced by  $(\mathcal{V}, \Phi)$  from  $A$ :

$$\mathcal{L}(\mathcal{G}) = \{x \mid A \xrightarrow{*} x \wedge x \in \mathcal{V}^*\}.$$

Let  $U \in \mathcal{V}$ . A parse of the string  $z$  into the symbol  $U$  is a sequence of syntactic rules  $\varphi_1, \varphi_2, \dots, \varphi_n$ , such that  $\varphi_j$  directly reduces  $z_{j-1}$  into  $z_j$  ( $j = 1 \dots n$ ), and  $z = z_0, z_n = U$ .

Assume  $z_k = U_1 U_2 \dots U_m$  (for some  $1 < k < n$ ). Then  $z_i$  ( $i < k$ ) must be of the form  $z_i = u_1 u_2 \dots u_m$ , where for each  $l = 1 \dots m$  either  $U_l \xrightarrow{*} u_l$ , or  $U_l = u_l$ . Then the canonical form of the section of the parse reducing  $z_i$  into  $z_k$  shall be  $\{\varphi_1\}\{\varphi_2\} \dots \{\varphi_m\}$ , where the sequence  $\{\varphi_l\}$  is the canonical form of the section of the parse reducing  $u_l$  into  $U_l$ . Clearly  $\{\varphi_l\}$  is empty, if  $U_l = u_l$ , and is canonical, if it consists of 1 element only..

The canonical parse is the parse which proceeds strictly from left to right in a sentence, and reduces a leftmost part of a sentence as far as possible before proceeding further to the right. In general, there may exist several canonical parses for a sentence, but every parse has only one canonical form.

An unambiguous syntax is a phrase structure syntax with the property that for every string  $x \in \mathcal{L}(\mathcal{G})$  there exists exactly one canonical parse.

It has been shown that there exists no algorithm which decides the ambiguity problem for any arbitrary syntax. However, a sufficient condition for a syntax to be unambiguous will subsequently be derived.

A method will be explained to determine whether a given syntax satisfies

this condition. . .

An environment  $\mathcal{E}$  is a set of variables whose values define the meaning of a sentence.

An interpretation rule  $\psi$  defines an action (or a sequence of actions) involving the variables of an environment  $\mathcal{E}$ .

A phrase structure programming language  $\mathcal{L}_p(\mathcal{G}, \Psi, \mathcal{E})$  is a phrase structure language  $\mathcal{L}(\mathcal{G})$ , where  $\mathcal{G}(\mathcal{V}, \Phi, \mathcal{B}, A)$  is a phrase structure syntax,  $\Psi$  is a set of (possibly empty) interpretation rules such that a unique one to one mapping exists between elements of  $\Psi$  and  $\Phi$ , and  $\mathcal{E}$  is an environment for the elements of  $\Psi$ . Instead of  $\mathcal{L}_p(\mathcal{G}, \Psi, \mathcal{E})$  we also write  $\mathcal{L}_p(\mathcal{V}, \Phi, \mathcal{B}, A, \Psi, \mathcal{E})$ .

The meaning  $m$  of a sentence  $x \in \mathcal{L}_p$  is the effect of the execution of the sequence of interpretation rules  $\psi_1, \psi_2 \dots \psi_n$  on the environment  $\mathcal{E}$ , where  $\phi_1 \phi_2 \dots \phi_n$  is a parse of the sentence  $x$  into the symbol  $A$  and  $\psi_i$  corresponds to  $\phi_i$  for all  $i$ .

It follows immediately that a programming language will have an unambiguous meaning, if and only if its underlying syntax is unambiguous. As a consequence, every sentence of the language has a well-defined meaning.

A sentence  $x_1 \in \mathcal{L}_p(\mathcal{G}_1, \Psi_1, \mathcal{E})$  is called equivalent to a sentence  $x_2 \in \mathcal{L}_p(\mathcal{G}_2, \Psi_2, \mathcal{E})$  (possibly  $\mathcal{G}_1 = \mathcal{G}_2, \Psi_1 = \Psi_2$ ), if and only if  $m(x_1)$  is equal to  $m(x_2)$ .

A programming language  $\mathcal{L}_p(\mathcal{G}_1, \Psi_1, \mathcal{E})$  is called equivalent to  $\mathcal{L}_p(\mathcal{G}_2, \Psi_2, \mathcal{E})$ , if and only if  $\mathcal{L}_{p1} = \mathcal{L}_{p2}$  and for every sentence  $x$ ,  $m_1(x)$  according to  $(\mathcal{G}_1, \Psi_1)$  is equal to  $m_2(x)$  according to  $(\mathcal{G}_2, \Psi_2)$ .

## B. Precedence Phrase Structure Systems

The definition of the meaning of a sentence requires that a sentence must be parsed in order to be evaluated or obeyed. Our prime attention will therefore be directed toward a constructive method for parsing. In the present chapter, a parsing algorithm will be described. It relies on certain relations between symbols. These relations can be determined for any given syntax. A syntax for which the relation between any two symbols is unique, is called a simple precedence syntax. Obviously, the parsing algorithm only applies to precedence phrase structure systems. It will then be shown that any parse in such a system is unique. The class of precedence phrase structure systems is only a restricted subset among all phrase structure systems. The definition of precedence relations will subsequently be generalized with the effect that the class of precedence phrase structure systems will be considerably enlarged.

### 1. The Parsing Algorithm for Simple Precedence Phrase Structure Languages.

In accordance with the definition of the canonical form of a generation tree or of a parse, a parsing algorithm must first detect the leftmost substring of the sentence to which a reduction is applicable. Then the reduction is to be performed and the same principle is applied to the new sentence. In order to detect the leftmost reducible substring, the algorithm to be presented here makes use of previously established noncommutative relations between symbols of  $\mathcal{U}$  which are chosen according to the following criteria:

- a. The relation  $\dot{=}$  holds between all adjacent symbols within a string which is directly reducible;

- b. The relation  $\prec$  holds between the symbol immediately preceding a reducible string and the leftmost symbol of that string;
- c. The relation  $\succ$  holds between the rightmost symbol of a reducible string and the symbol immediately following that string.

The process of detecting the leftmost reducible substring now consists of scanning the sentence from left to right until the first symbol pair is found so that  $S_i \succ S_{i+1}$ , then to retreat back to the last symbol pair for which  $S_{j-1} \prec S_j$  holds.  $S_j \dots S_i$  is then the sought substring; it is replaced by the symbol resulting from the reduction. The process then repeats itself. At this point it must be noted that it is not necessary to start scanning at the beginning of the sentence, since all symbols  $S_k$  for  $k < j$  have not been altered, but that the search for the next  $\succ$  can start at the place of the previous reduction.

In the following formal description of the algorithm the original sentence is denoted by  $P_1 \dots P_n$ .  $k$  is the index of the last symbol scanned. For practical reasons, all scanned symbols are copied and renamed  $S_j \dots S_i$ . The reducible substring therefore will always be  $S_j \dots S_i$  for some  $j$ . Internal to the algorithm, there exists a symbol  $\perp$  initializing and terminating the process. To any symbol  $S$  of  $\mathcal{V}$  it has the relations-  $\perp \prec S$  and  $S \succ \perp$ .

We assume that  $P_0 = P_{n+1} = \perp$ .

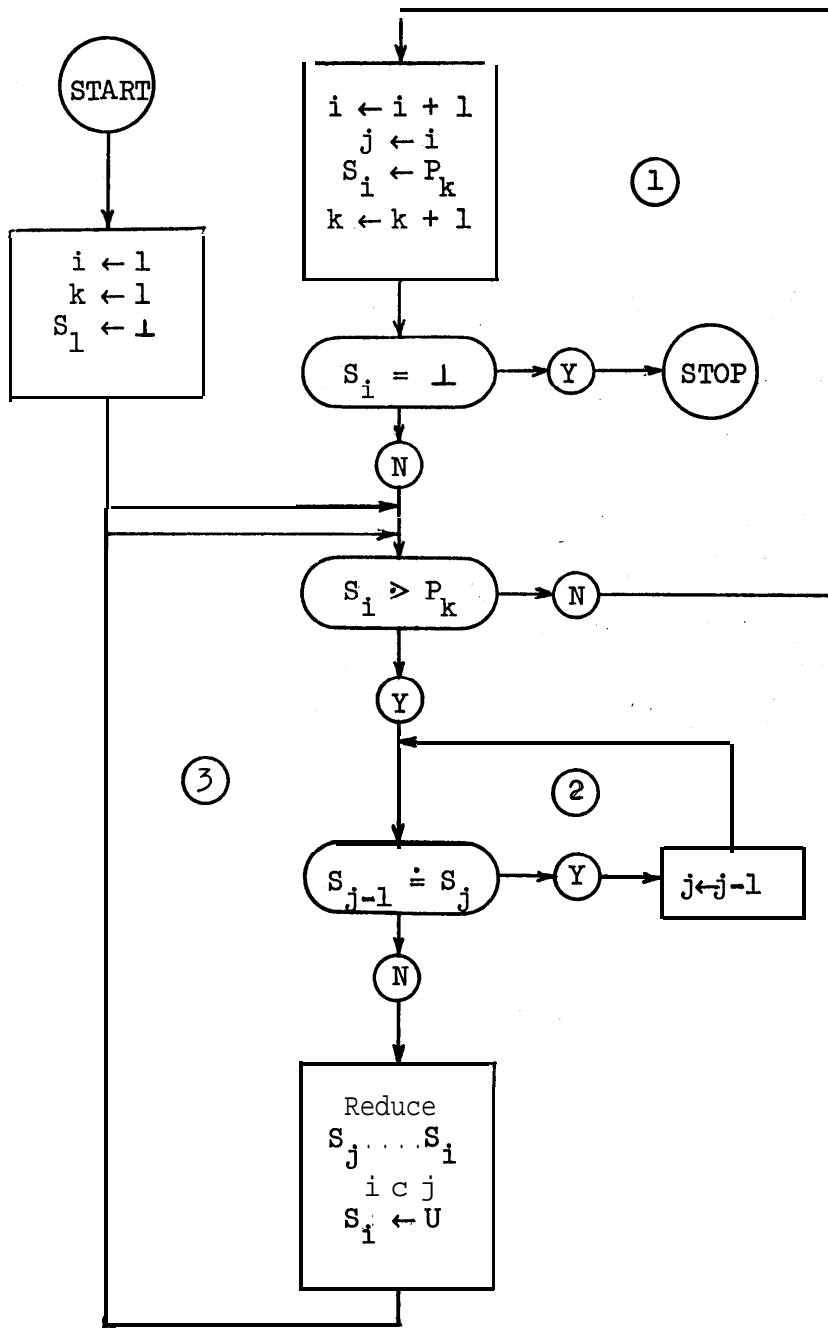

Algorithm for Syntactic Analysis



Comments to the Algorithm:

- ① Copy the string P into S and advance until a relation  $\triangleright$  is encountered;
- ② Retreat backward across the reducible substring;
- ③ A reduction has been made. Resume the search for  $\triangleright$ .

The step denoted by "Reduce  $S_j \dots S_i$ " requires that the reducible substring is identified in order to obtain the symbol resulting from the reduction. If the parsed sentence is to be evaluated, then the interpretation rule  $\psi_l$  corresponding to the syntactic rule  $\phi_l$ :  $u \rightarrow S_j \dots S_i$  is identified and obeyed.

## 2. An Algorithm to Determine the Precedence Relations.

The definition of the precedence relations can be formalized in the following way:

- a. For any ordered pair of symbols  $(S_i, S_j)$ ,  $S_i \doteq S_j$ , if and only if there exists a syntactic rule of the form  $u \rightarrow xS_iS_jy$ , for some symbol U and some (possibly empty) strings x, y.
- b. For any ordered pair of symbols  $(S_i, S_j)$ ,  $S_i \triangleleft S_j$ , if and only if there exists a syntactic rule of the form  $u \rightarrow xS_iU_jy$ , for some U, x, y,  $U_j$ , and there exists a generation  $U_j \xrightarrow{*} S_jz$ , for some string z.
- c. For any ordered pair of symbols  $(S_i, S_j)$ ,  $S_i \triangleright S_j$ , if and only if
  1. there exists a syntactic rule of the form  $U \rightarrow xU_kS_jy$ , for some U, x, y,  $U_k$ , and there exists a generation  $U_k \xrightarrow{*} zS_i$  for some string z, or

2. there exists a syntactic rule of the form  $U \rightarrow xU_k U_\ell y$ ,  
 for some  $U, x, y, U_k, U_\ell$ , and there exist generations  
 $U_k \xrightarrow{*} z s_i$  and  $U_\ell \xrightarrow{*} s_j w$  for some strings  $z, w$ .

We now introduce the sets of leftmost and rightmost symbols of a non-basic symbol  $U$  by the following definitions:

$$\mathcal{L}(U) = \{S \mid \exists z (U \xrightarrow{*} Sz)\}$$

$$\mathcal{R}(U) = \{S \mid \exists z (U \xrightarrow{*} zS)\}$$

Now the definitions a. b. c. can be reformulated as:

$$a. S_i \doteq S_j \iff \exists \varphi (\varphi: U \rightarrow xS_i S_j y)$$

$$b. S_i \triangleleft S_j \iff \exists \varphi (\varphi: U \rightarrow xS_i U_\ell y) \wedge S_j \in \mathcal{L}(U_\ell)$$

$$c. S_i \triangleright S_j \iff \exists \varphi (\varphi: U \rightarrow xU_k S_j y) \wedge S_i \in \mathcal{R}(U_k) \vee \\ \exists \varphi (\varphi: U \rightarrow xU_k U_\ell y) \wedge S_i \in \mathcal{R}(U_k) \wedge S_j \in \mathcal{L}(U_\ell)$$

These definitions are equivalent to the definitions of the precedence relations, if  $\Phi$  does not contain any rules of the form  $u \rightarrow \Lambda$ , where  $\Lambda$  denotes the empty string.

The definition of the sets  $\mathcal{L}$  and  $\mathcal{R}$  is such that an algorithm for effectively creating the sets is evident. A symbol  $S$  is a member of  $\mathcal{L}(U)$ , if

- There exists a syntactic rule  $\varphi: U \rightarrow Sx$ , for some  $x$ , or
- There exists a syntactic rule  $\varphi: u \rightarrow U_1 x$ , and  $S \in \mathcal{L}(U_1)$ ;

i.e.

$$\mathcal{L}(U) = \{S \mid \exists \varphi: U \rightarrow Sx \vee \exists \varphi: u \rightarrow U_1 x \wedge S \in \mathcal{L}(U_1)\}$$

Analogously:

$$\mathcal{R}(U) = \{S \mid \exists \varphi: U \rightarrow xS \vee \exists \varphi: u \rightarrow xU_1 \wedge S \in \mathcal{R}(U_1)\}$$

The algorithm for finding  $\mathcal{L}$  and  $\mathcal{R}$  for all symbols  $U \in \mathcal{V}-\mathcal{B}$  involves searching  $\Phi$  for appropriate syntactic rules. In practice, this turns out to be a rather intricate affair, because precautions must be taken when recursive definitions are used. An algorithm is presented in Appendix I as part of an Extended ALGOL program for the Burroughs B5500 computer.

The precedence relations can be represented by a matrix  $\underline{M}$  with elements  $\underline{M}_{ij}$  representing the relation between the ordered symbol pair  $(S_i, S_j)$ . The matrix clearly has as many rows and columns as there are symbols in the vocabulary  $\mathcal{V}$ .

Assuming that an arbitrary ordering of the symbols of  $\mathcal{V}$  has been made ( $\mathcal{V} = \{S_1, S_2, \dots, S_n\}$ ), an algorithm for the determination of the precedence matrix  $M$  can be indicated as follows:

For every element  $\phi$  of  $\Phi$  which is of the form

$$U \rightarrow S_1 S_2 \dots S_m$$

and for every pair  $S_i, S_{i+1}$  ( $i = 1 \dots m - 1$ ) assign

- a.  $\doteq$  to  $\underline{M}_{i, i+1}$  ;
- b.  $\triangleleft$  to all  $\underline{M}_{i, k}$  with row index  $k$  such that  $S_k \in \mathcal{L}(S_{i+1})$ ;
- c.  $\triangleright$  to all  $\underline{M}_{k, i+1}$  with column index  $k$  such that  $S_k \in \mathcal{R}(S_i)$ ;
- d.  $\bullet >$  to all  $\underline{M}_{l, k}$  with indices  $l, k$  such that  $S_l \in \mathcal{R}(S_i)$  and  $S_k \in \mathcal{L}(S_{i+1})$  .

Assignments under b. occur only if  $S_{i+1} \in \mathcal{V}-\mathcal{B}$ , under c. only if  $S_i \in \mathcal{V}-\mathcal{B}$ , and under d. only if both  $S_i, S_{i+1} \in \mathcal{V}-\mathcal{B}$ , because  $\mathcal{L}(S)$  and  $\mathcal{R}(S)$  are empty sets for all  $S \in \mathcal{B}$ .

This algorithm appears as part of the ALGOL program listed in Appendix I.

A syntax is a simple precedence syntax, if and only if at most one relation holds between any ordered pair of symbols.

3. Examples

a.  $\mathcal{G}_1 = (\mathcal{V}_1, \Phi_1, \mathcal{B}_1, S)$

$$\mathcal{V}_1 = \{S, H, \lambda, "\}$$

$$\mathcal{B}_1 = \{CA, "\}$$

$$\Phi_1 : \begin{array}{l} S \rightarrow H \text{ " } \\ H \rightarrow \text{ " } \\ H \rightarrow H \lambda \\ H \rightarrow H S \end{array}$$

Assume that S stands for 'string' and H for 'head', then this phrase structure system would define a string as consisting of a sequence of string elements enclosed in quote-marks, where an element is either  $\lambda$  or another (nested) string.

U	$\mathcal{L}(U)$	$\mathcal{R}(U)$
S	" H	"
H	" H	" $\lambda$ S

<u>M</u>	S	H	$\lambda$	"
S	>	>	>	>
H	$\doteq$	<	$\doteq$	$\leq$
$\lambda$	>	>	>	>
"	>	>	>	>

Since both  $H \doteq \text{"}$  and  $H < \text{"}$ ,  $\mathcal{G}_1$  is not a precedence syntax. It is intuitively clear that either nested strings should be delineated by distinct opening and closing marks ( $\mathcal{G}_2$ ), or that no nested strings should be allowed ( $\mathcal{G}_3$ ).

b  $\mathcal{G}_2 = (\mathcal{V}_2, \Phi_2, \mathcal{R}_2, S$

$$\mathcal{V}_2 = \{S, H, \lambda, \epsilon, '\}$$

$$\mathcal{R}_2 = \{\lambda, \epsilon, '\}$$

$$\begin{aligned} \Phi_2 : S \rightarrow H & \text{ } (\phi_1) \\ H \rightarrow \epsilon & \text{ } (\phi_2) \\ H \rightarrow H\lambda & \text{ } (\phi_3) \\ H \rightarrow HS & \text{ } (\phi_4) \end{aligned}$$

U	$\mathcal{R}(U)$	$\mathcal{R}(U)$
S	$\epsilon$ H	$'$
H	$\epsilon$ H	$\lambda$ S $'$

$\overline{M}$	S	H	$\lambda$	$\epsilon$	$'$
S	$\succ$	$\succ$	$\succ$	$\succ$	$\succ$
H	$\neq$	$\prec$	$\neq$	$\prec$	$\neq$
$\lambda$	$\succ$	$\succ$	$\succ$	$\succ$	$\succ$
$\epsilon$	$\succ$	$\succ$	$\succ$	$\succ$	$\succ$
$'$	$\succ$	$\succ$	$\succ$	$\succ$	$\succ$

$\mathcal{G}_2$  is a precedence syntax

c.  $\mathcal{G}_3 = (\mathcal{V}_3, \Phi_3, \mathcal{R}_3, S$

$$\begin{aligned} \Phi_3 : S \rightarrow H & \text{ } '' \\ H \rightarrow '' & \text{ } \\ H \rightarrow H\lambda & \end{aligned}$$

U	$\mathcal{R}(U)$	$\mathcal{R}(U)$
S	'' H	''
H	'' H	'' $\lambda$



This theorem is proven, if it can be shown that in any sentence its directly reducible parts are disjoint. Then the algorithm, proceeding strictly from left to right, produces the canonical parse, which is unique, because no reducible substring can apply to more than one syntactic rule.

The proof that all directly reducible substrings are disjoint is achieved indirectly: Suppose that the string  $S_1 \dots S_n$  contain two directly reducible substrings  $S_1 \dots S_k$  (a.) and  $S_{ij} \dots S_\ell$  (b.), where  $1 \leq i \leq j \leq k \leq \ell \leq n$ . Then because of a. it follows from the definition of the precedence relations that  $S_{j-1} \dot{=} S_j$  and  $S_k \dot{>} S_{k+1}$ , and because of b.  $S_{j-1} \dot{<} S_j$  and  $S_k \dot{=} S_{k+1}$ . Therefore this sentence cannot belong to a precedence grammar.

Since in particular the leftmost reducible substring is unique, the syntactic rule to be applied is unique. Because the new sentence again belongs to the precedence language, the next reduction is unique again. It can be shown by induction, that therefore the entire parse must be unique.

From the definition of the meaning of a phrase structure programming language it follows that its meaning is unambiguous for all sentences, if the underlying syntax is a precedence syntax.

##### 5. Precedence Functions.

The given parsing algorithm refers to a matrix of precedence relations with  $n^2$  elements, where  $n$  is the number of symbols in the language. For practical compilers this would in most cases require an extensive amount of storage space. Often the precedence relations are such that two numeric functions  $(f, g)$  ranging over the set of symbols can

be found, such that for all ordered pairs  $(S_i, S_j)$

- a.  $f(S_i) = g(S_j) \iff S_i \doteq S_j$
- b.  $f(S_i) < g(S_j) \iff S_i \triangleleft S_j$
- c.  $f(S_i) > g(S_j) \iff S_i \triangleright S_j$

If these functions exist and the parsing algorithm is adjusted appropriately, then the amount of elements needed to represent the precedence information reduces from  $n^2$  to  $2n$ . An algorithm for deciding whether the functions exist and for finding the functions if they exist is given as part of the ALGOL program in Appendix-1 .

In example  $\mathcal{G}_2$  e.g. the precedence matrix can be represented by the two functions  $f$  and  $g$ , where

$S =$	$s$	$h$	$\lambda$	$'$	$,$
$f(S) =$	3	1	3	3	3
$g(s) =$	1	2	1	2	1

A precedence phrase structure syntax for which these precedence functions do not exist is given presently:

$$\mathcal{V} = \{A, B, C, \lambda, [, ]\}$$

$$\mathcal{B} = \{\lambda, [, ]\}$$

$$\Phi: A \rightarrow C B ]$$

$$A \rightarrow [ ]$$

$$B \rightarrow \lambda$$

$$B \rightarrow \lambda A$$

$$B \rightarrow A$$

$$C \rightarrow [$$

It can be verified that this is a precedence syntax and in particular the following precedence relations can be derived:



$$\lambda \prec [ , [ \succ [ , [ \dot{=} ] , \lambda \succ ]$$

Precedence functions  $f$  and  $g$  would thus have to satisfy

$$f(\lambda) < g([) < f([) = g([) < f(\lambda)$$

which clearly is a contradiction. Precedence functions therefore do not exist for this precedence syntax.

## 6. Higher Order Precedence Syntax.

It is the purpose of this chapter to redefine the precedence relationships more generally, thus enlarging the class of precedence phrase structure systems. This is desirable, since for precedence languages a constructive parsing algorithm has been presented which is instrumental in the definition of the meaning of the language. The motivation for the manner in which the precedence relationships will be generalized is first illustrated in an informal way by means of examples. These examples are phrase structure systems which for one or another reason might be likely to occur in the definition of a language, but which also violate the rules for simple precedence syntax.

### Example 1.

$$\mathcal{V} = \{A, B, ;, S, D\}$$

$$\mathcal{B} = \{;, S, D\}$$

$$\begin{aligned} \Phi: & A \rightarrow B \\ & A \rightarrow D ; A \\ & B \rightarrow S \\ & B \rightarrow B ; S \end{aligned}$$

$$S \in \$(A), \text{ thus } ; \prec S, \text{ and also } ; \dot{=} S.$$

This syntax produces sequences of D's separated by ";", followed by a sequence of symbols S, also separated by ";". A parse is constructed as follows:



$D \in R(A)$ , thus  $D \succ ;$  and also  $D \doteq ;$

This syntax produces the same strings as the preceding one, but with a different syntactic structure:

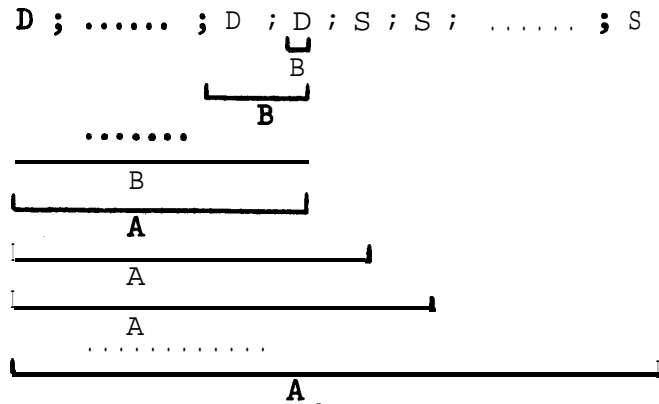

Here the same difficulty arises upon encountering the symbol sequence "D;". The decision whether to include both symbols in the same syntactic category or not can be reached upon investigating the following symbol. Explicitly, a symbol should be related to the subsequent string of 2 symbols, i.e.

$$D \doteq ;D \text{ and } D \succ ;S .$$

Example 3:

$$\mathcal{U} = \{A, B, \lambda, ;, [, ]\}$$

$$\mathcal{B} = \{\lambda, ;, [, ]\}$$

$$\begin{aligned} \Phi : A &\rightarrow B ; B \\ B &\rightarrow [ A ] \\ B &\rightarrow [ \lambda ] \\ B &\rightarrow \lambda \end{aligned}$$

Since  $\lambda \in \mathcal{L}(A)$  and  $A \in \mathcal{R}(A) : [ \langle \lambda \text{ and } \lambda \rangle ]$ . But also  $[ \doteq \lambda \text{ and } \lambda \doteq ]$ .

In this case the following relations must be established to resolve the ambiguity.

$$[ \doteq \lambda ], [ \langle \lambda ; , ; \lambda \rangle ] \text{ and } [ \lambda \doteq ] .$$

This syntax therefore combines the situations arising in Examples 1 and 2. Obviously, examples could be created where the strings to be related would be of length greater than 2. We will therefore call a precedence phrase structure system to be of order  $(m, n)$ , if unique precedence relations can be established between strings of length  $\leq m$  and strings of length  $< n$ . Subsequently, a more precise definition will be stated. A set of extended rules must be found which define the generalized precedence relations. The parsing algorithm, however, remains the same, with the exception that not only the symbols  $S_i$  and  $P_k$  be related, but possibly the strings  $S_{i-m} \dots S_i$  and  $P_k \dots P_{k+n}$ .

The definitions of the relations  $\dot{=}$ ,  $\dot{<}$ ,  $\dot{>}$  is as follows: Let  $x = s_{-m} \dots S_{-1}$ ,  $y = S_1 \dots S_n$ , let  $u, v, u', v' \in \mathcal{V}^*$  and  $U, U_1, U_2 \in \mathcal{V}^+ \mathcal{B}$ , then

a.  $x \dot{=} y$ , if and only if there exists a syntactic rule

$$u \rightarrow uS_{-1}S_1v, \text{ and} \\ uS_{-1} \xrightarrow{*} u'x, S_1v \xrightarrow{*} yv' ;$$

b.  $x \dot{<} y$ , if and only if there exists a syntactic rule

$$u \rightarrow uS_{-1}U_1v, \text{ and} \\ uS_{-1} \xrightarrow{*} u'x, U_1v \xrightarrow{*} yv' ;$$

c.  $x \dot{>} y$ , if and only if there exists a syntactic rule

$$U \rightarrow uU_1S_1v, \text{ and} \\ uU_1 \xrightarrow{*} u'x, S_1v \xrightarrow{*} yv', \text{ or there exists a syntactic rule} \\ U \rightarrow uU_1U_2v \text{ and } uU_1 \xrightarrow{*} u'x, U_2v \xrightarrow{*} yv' .$$

A syntax is said to be a precedence syntax of order  $(m,n)$ , if and only if

- a. it is not a precedence syntax of degree  $(m', n')$  for  $m' < m$  or  $n' < n$ , and
- b. for any ordered pair of strings  $s_{-m}' \dots s_{-1}', s_1 \dots s_n'$ , where  $m' < m$  and  $n' < n$  either at most one of the  $\exists$  relations  $\ll \doteq \bullet \gg$  holds or otherwise b. is satisfied for the pair

$$s_{-(m'+1)} \dots s_{-1}' \bullet s_1 \dots s_{n'+1}'.$$

A precedence syntax of order  $(1,1)$  is called a simple precedence syntax. With the help of the sets of leftmost and rightmost strings, the definitions of the precedence relations can be reformulated analogously to their counterparts in section 2b, subject to the condition that there exists no rule  $U \rightarrow A$ .

- a.  $x \doteq y \leftrightarrow \exists \varphi (\varphi: U \rightarrow u s_{-1} s_1 v)$   
 $\wedge (u' s_{-m} \dots s_{-2} = u \vee s_{-m} \dots s_{-2} \in \mathcal{R}^{(m-1)}(u))$   
 $\wedge (s_2 \dots s_n v' = v \vee s_2 \dots s_n \in \mathcal{L}^{(n-1)}(v))$
- b.  $x \ll y \leftrightarrow \exists \varphi (\varphi: u \rightarrow u s_{-1} U_1 v)$   
 $\wedge (u' s_{-m} \dots s_{-2} = u \vee s_{-m} \dots s_{-2} \in \mathcal{R}^{(m-1)}(u))$   
 $\wedge (s_1 \dots s_n \in \mathcal{L}^{(n)}(U_1 v))$
- c.  $x \gg y \leftrightarrow \exists \varphi (\varphi: u \rightarrow u U_1 s_1 v)$   
 $\wedge (s_{-m} \dots s_{-1} \in \mathcal{R}^{(m)}(u U_1))$   
 $\wedge (s_1 \dots s_n v' = v \vee s_2 \dots s_n \in \mathcal{L}^{(n-1)}(v))$   
or  
 $\exists \varphi (\varphi: u \rightarrow u U_1 U_2 v)$   
 $\wedge (s_{-m} \dots s_{-1} \in \mathcal{R}^{(m)}(u U_1)) \wedge (s_1 \dots s_n \in \mathcal{L}^{(n)}(U_2 v))$

$\mathcal{L}^{(n)}(s)$  and  $\mathcal{R}^{(n)}(s)$  are then defined as follows:

1.  $z = z_1 \dots z_n \in \mathcal{L}^{(n)}(u) \leftrightarrow \exists k(1 \leq k \leq n) \ni$   
 $((z_1 \dots z_k \in \mathcal{L}^{(k)}(u)) \wedge (z_{k+1} \dots z_n u' = u \vee z_{k+1} \dots z_n z \in \mathcal{L}^{(n-k)}(u)))$
- 1a.  $z = z_1 \dots z_n \in \mathcal{L}^{(n)}(U) \leftrightarrow \exists k(0 \leq k \leq n) \ni$   
 $(U \rightarrow z_1 \dots z_k u \wedge z_{k+1} \dots z_n \in \mathcal{L}^{(n-k)}(u))$
2.  $z = z_n \dots z_1 \in \mathcal{R}^{(n)}(u) \leftrightarrow \exists k(1 \leq k \leq n) \ni$   
 $((u' z_n \dots z_{k+1} = u \vee z_n \dots z_{k+1} \in \mathcal{R}^{(n-k)}(u)) \wedge (z_k \dots z_1 \in \mathcal{R}^{(k)}(u)))$
- 2a.  $z = z_n \dots z_1 \in \mathcal{R}^{(n)}(U) \leftrightarrow \exists k(0 \leq k \leq n) \ni$   
 $(u \rightarrow u z_k \dots z_1 \wedge z_n \dots z_{k+1} \in \mathcal{R}^{(n-k)}(u))$

These formulae indicate the method for effectively finding the sets  $\mathcal{L}$  and  $\mathcal{R}$  for all symbols in  $\mathcal{V}\text{-}\mathcal{B}$ . In particular, we obtain for  $\mathcal{L}^{(1)}$  and  $\mathcal{R}^{(1)}$  the definitions for  $\mathcal{L}$  and  $\mathcal{R}$  without superscript as defined in section 2b.

Although for practical purposes such as the construction of a useful programming language no precedence syntax of order greater than (2,2) -- or even (2,1) -- will be necessary, a general approach for the determination of the precedence relations of any order shall be outlined subsequently:

First it is to be determined whether a given syntax is a precedence syntax of order (1,1). If it is not, then for all pairs of symbols  $(s_i, s_k)$  between which the relationship is not unique, it has to be determined whether all relations will be unique between either  $(s_j s_i, s_k)$  or  $(s_i, s_k s_j)$ , where  $s_j$  ranges over the entire vocabulary. According to the outcome, one obtains a precedence syntax of order (2,1), (1,2) or (2,2), or if some relations are still not unique, one has to try for even higher orders. If at some stage it is not possible to determine relations

between the strings with the appended symbol  $s_j$  ranging over the entire vocabulary, then the given syntax is no precedence syntax at all.

Example:

$$\mathcal{V} = \{A, B, \lambda, [, ]\}$$

$$\mathcal{B} = \{\lambda, [, ]\}$$

$$\begin{aligned} \Phi : A &\rightarrow B \\ A &\rightarrow [ B ] \\ B &\rightarrow \lambda \\ B &\rightarrow [ \lambda ] \end{aligned}$$

The conflicting relations are  $[ \prec \lambda, [ \doteq \lambda, \lambda \doteq ]$  and  $\lambda \succ ]$ . But a relation between  $(S[, \lambda)$  or  $(A, ]S)$  can be established for no symbol  $S$  whatsoever, and between  $([, \lambda s_1)$  and  $(s_2 \lambda, ])$  only for  $s_1 = ]$  and  $s_2 = [$ . Thus this is no precedence syntax.

Clearly there exist two different parses for the string  $[A]$ , namely

$$\begin{array}{ccc} [ \lambda ] & \text{and} & [ \lambda ] \\ \underbrace{\quad} & & \underbrace{\quad} \\ B & & B \\ \underbrace{\quad} & & \underbrace{\quad} \\ A & & A \end{array}$$

The underlying phrase structure systems in section III.3 and chapter IV will be simple precedence phrase structure systems.

### C. An Example

A simple phrase structure programming language shall serve as an illustration of the presented concepts. This language contains the following constructs which are well-known from ALGOL60: Variables, arithmetic expressions, assignment statements, declarations and the block structure. The meaning of the language is explained in terms of an array of variables,

called the 'value stack', which has to be understood as being associated with the array  $\underline{S}$  which is instrumental in the parsing algorithm. The variable  $\underline{V}_i$  represents the 'value' associated with the symbol  $\underline{S}_i$ . E.g., the interpretation rule  $\psi_{11}$  corresponding to the syntactic rule  $\phi_{11}$  determines the value of the resulting symbol expr- as the sum of the values of the symbols expr- and term belonging to the string to be reduced.

$$\phi_{11} : \underline{\text{expr-}} \rightarrow \underline{\text{expr-}} + \text{term}$$

$$\psi_{11} : \underline{v}_j \leftarrow \underline{v}_j + \underline{v}_i, \quad [V(\underline{\text{expr-}}) \leftarrow V(\underline{\text{expr-}}) + V(\underline{\text{term}})]$$

Note that the string to be reduced has been denoted by  $\underline{S}_{-3} \dots \underline{S}_i$  in the parsing algorithm of section III.2a. Instead of thus making explicit reference to a particular parsing algorithm,  $\underline{V}_i \dots \underline{V}_j$ , the values of the symbols  $\underline{S}_i \dots \underline{S}_j$ , can be denoted explicitly, i.e. instead of  $\underline{V}_i$  and  $\underline{V}_j$ . in  $\psi_{11}$  one might write  $V(\text{term})$  and  $V(\underline{\text{expr-}})$  respectively. For the sake of brevity, the subscripts  $i$  and  $j$  have been preferred here.

A second set of variables is called the 'name stack'. It serves to represent a second value of certain symbols, which can be considered as a 'name'. The symbol decl is actually the only symbol with two values; it represents a variable of the program in execution which has a name (namely its associated identifier) and a value (namely the value last assigned to it by the program). The syntax of the language is such that the symbol decl remains in the parse-stack  $S$  as long as the declaration is valid, i.e. until the block to which the declaration belongs is closed. This is achieved by defining the sequence of declarations in the head of a block by the right - recursive syntactic rule  $\phi_4$ . The



parse of a sequence of declarations illustrates that the declarations can only be involved in a reduction together with a body- symbol after a symbol body- has originated through some other syntactic reduction. This, in turn, is only possible when the symbol end is encountered. The end symbol then initiates a whole sequence of reductions which result in the collapsing of the part of the stack which represented the closing block. On the other hand, the sequence of statements which constitutes the imperative part of a block, is defined by the left-recursive syntactic formula  $\Phi_6$ . Thus a statement reduces with a preceding statement-list into a statement-list immediately, because there is no need to retain information about the executed statement in the value-stack.

This is a typical example where the syntax is engaged in the definition of not only the structure but also the meaning of a language. The consequence is that in constructing a syntax one has to be fully aware of the meaning of a constituent of the language and its interaction with other constituents. Many other such examples will be found in chapter IV of this article. It is, however, not possible to enumerate and discuss every particular consideration which had to be made during the construction of the language. Only a detailed study and analysis of the language can usually reveal the reasons for the many decisions which were taken in its design.

Subsequently the formal definition of the simple phrase structure language is given:

$$\mathcal{L}_p = (\mathcal{V}, \Phi, \mathcal{B}, \text{program}, @, \&)$$

$$\mathcal{V} - \mathcal{B} = \{ \text{program} \mid \text{block} \mid \text{body} \mid \text{body-} \mid \text{decl} \mid \text{statement} \mid \text{statlist} \mid \text{expr} \mid \text{exp:r-} \mid \text{term} \mid \text{term-} \mid \text{factor} \mid \text{var} \mid \text{number} \mid \text{digit} \mid \perp \}$$

$$\mathcal{B} = \{ \lambda \mid \text{begin} \mid \text{end} \mid ; \mid , \mid \leftarrow \mid + \mid - \mid \times \mid / \mid ( \mid ) \mid 0 \mid 1 \mid 2 \mid 3 \mid 4 \mid 5 \mid 6 \mid 7 \mid 8 \mid 9 \mid \text{new} \mid \perp \}$$

$$\mathcal{E} = \{ \underline{S}, \underline{V}, \underline{W}, i \}$$

$\Phi$  :  $\varphi_1$  : program  $\rightarrow$   $\perp$  block  $\perp$   
 $\varphi_2$  : block  $\rightarrow$  begin body end  
 $\varphi_3$  : body  $\rightarrow$  body-  
 $\varphi_4$  : body-  $\rightarrow$  decl ; body-  
 $\varphi_5$  : body-  $\rightarrow$  statlist  
 $\varphi_6$  : statlist  $\rightarrow$  statlist , statement  
 $\varphi_7$  : statlist  $\rightarrow$  statement  
 $\varphi_8$  : statement  $\rightarrow$  var  $\leftarrow$  expr  
 $\varphi_9$  : statement  $\rightarrow$  block  
 $\varphi_{10}$  : expr  $\rightarrow$  expr-  
 $\varphi_{11}$  : expr-  $\rightarrow$  expr- + term  
 $\varphi_{12}$  : expr-  $\rightarrow$  expr- - term  
 $\varphi_{13}$  : expr-  $\rightarrow$  - term  
 $\varphi_{14}$  : expr-  $\rightarrow$  term  
 $\varphi_{15}$  : term  $\rightarrow$  term-  
 $\varphi_{16}$  : term-  $\rightarrow$  term-  $\times$  factor  
 $\varphi_{17}$  : term-  $\rightarrow$  term- / factor  
 $\varphi_{18}$  : term-  $\rightarrow$  factor  
 $\varphi_{19}$  : factor  $\rightarrow$  var  
 $\varphi_{20}$  : factor  $\rightarrow$  ( expr )  
 $\varphi_{21}$  : factor  $\rightarrow$  number  
 $\varphi_{22}$  : var  $\rightarrow$   $\lambda$   
 $\varphi_{23}$  : number  $\rightarrow$  digit  
 $\varphi_{24}$  : number  $\rightarrow$  number digit  
 $\varphi_{25}$  : decl  $\rightarrow$  new  $\lambda$   
 $\varphi_{26}$  : digit  $\rightarrow$  0  
 $\varphi_{27}$  : digit  $\rightarrow$  1  
.....  
 $\varphi_{35}$  : digit 9

$\Psi$  :  $\psi_1$  :  $\wedge$  (empty)  
 $\psi_2$  :  $\wedge$   
 $\psi_3$  :  $\wedge$   
 $\psi_4$  :  $\underline{w}_j \leftarrow \Omega$   
 $\psi_5$  :  $\wedge$   
 $\psi_6$  : A  
 $\psi_7$  : A  
 $\psi_8$  :  $\underline{v}_j \leftarrow \underline{v}_i$   
 $\psi_9$  :  $\wedge$   
 $\psi_{10}$  : A  
 $\psi_{11}$  :  $\underline{v}_j \leftarrow \underline{v}_j + \underline{v}_i$   
 $\psi_{12}$  :  $\underline{v}_j \leftarrow \underline{v}_j - \underline{v}_i$   
 $\psi_{13}$  :  $\underline{v}_j \leftarrow - \underline{v}_i$   
 $\psi_{14}$  :  $\wedge$   
 $\psi_{15}$  :  $\wedge$   
 $\psi_{16}$  :  $\underline{v}_j \leftarrow \underline{v}_j \times \underline{v}_i$   
 $\psi_{17}$  :  $\underline{v}_j \leftarrow \underline{v}_j / \underline{v}_i$   
 $\psi_{18}$  :  $\wedge$   
 $\psi_{19}$  :  $\underline{v}_j \leftarrow \underline{v}_{\underline{v}_j}$   
 $\psi_{20}$  :  $\underline{v}_j \leftarrow \underline{v}_{j+1}$   
 $\psi_{21}$  :  $\wedge$   
 $\psi_{22}$  :  $t \leftarrow j$   
 $t \leftarrow t - 1$   
 $\underline{if} \ t = 0 \ \underline{then}$   $\left. \begin{array}{l} \underline{if} \ \underline{w}_t \neq \underline{s}_j \ \underline{then} \\ \underline{v}_j \leftarrow t \end{array} \right\} \text{ERROR}$   
 $\psi_{23}$  :  $\wedge$   
 $\psi_{24}$  :  $\underline{v}_j \leftarrow \underline{v}_j \times 10$   
 $\underline{v}_j \leftarrow \underline{v}_j + \underline{v}_i$   
 $\psi_{25}$  :  $\underline{w}_j \leftarrow \underline{s}_i$   
 $\underline{v}_j \leftarrow \Omega$   
 $\psi_{26}$  :  $\underline{v}_j \leftarrow 0$   
 $\psi_{27}$  :  $\underline{v}_j \leftarrow 1$   
.....  
 $\psi_{35}$  :  $\underline{v}_j \leftarrow 9$

Notes:

1. The branch in rule  $\psi_{22}$  labelled with ERROR is an example for the indication of a 'semantic error' in  $\mathcal{L}_p$ . By 'semantic error' is in general meant a reaction of an interpretation rule which is not explicitly defined. In the example of  $\psi_{22}$  the labelled branch is followed when no identifier equal to  $\underline{S}_i$  is found in the W stack, i.e. when an 'undeclared' identifier is encountered.
2. The basic symbol  $\lambda$  in  $\mathcal{V}$  is here meant to act as a representative of the class of all identifiers. Nothing will be said about the representation of identifiers.

On the subsequent pages follow the sets of leftmost and rightmost symbols  $\mathcal{L}$  and  $\mathcal{R}$ , the matrix  $\underline{M}$  of precedence relations, and the precedence functions  $f$  and  $g$ , all of which were determined by the syntax-processor program listed in Appendix I.

\*\*\* LEFTMOST SYMBOLS \*\*\*

BLOCK	BEGIN									
BODY	BODY-	DECL	NEW	STATLIST	STATEMENT	VAR	IDENT	BLOCK	BEGIN	
BODY-	DECL	NEW	STATLIST	STATEMENT	VAR	IDENT	BLOCK	BEGIN		
DECL	NEW	STATLIST	STATEMENT	VAR	IDENT	BLOCK	BEGIN			
STATLIST	STATEMENT	VAR	IDENT	BLOCK	BEGIN					
STATEMENT	VAR	IDENT	BLOCK	BEGIN						
VAR	IDENT	BLOCK	BEGIN							
EXPR	EXPR-	=	TERM	TERM-	FACTOR	VAR	IDENT	(	DIGIT	0
	1	2	3	4	5	6	7	8	9	NUMBER
EXPR-	EXPR-	=	TERM	TERM-	FACTOR	VAR	IDENT	(	DIGIT	0
	1	2	3	4	5	6	7	9	9	NUMBER
TERM	TERM-	FACTOR	VAR	IDENT	(	DIGIT	0	1	2	3
	4	5	6	8	9	NUMBER	0	1	2	3
TERM-	TERM-	FACTOR	JAR	IDENT	(	DIGIT	0	1	2	3
	4	5	6	9	6	YUYBER	9			
FACTOR	VAR	IDENT	(	DIGIT	0	1	2	3	4	5
	6	7	8	9	NUMBER					
NUMBER	DIGIT	0	1	2	3	4	5	6	7	9
	9	NUMBER								
DIGIT	0	1	2	3	4	5	6	7	8	9

\*\*\* RIGHTMOST SYMBOLS \*\*\*

BLOCK	END									
BODY	BODY-	STATLIST	STATEMENT	EXPR	EXPR-	TERM	TERM-	FACTOR	VAR	IDENT
	)	NUMBER	DIGIT	0	1	2	3	4	5	6
	7	8	9	BLOCK	END					
BODY-	BODY-	STATLIST	STATEMENT	EXPR	EXPR-	TERM	TERM-	FACTOR	VAR	IDENT
	)	NUMBER	DIGIT	0	1	2	3	4	5	6
	7	8	9	BLOCK	END					
DECL	IDENT	EXPR	EXPR-	TERM	TERM-	FACTOR	VAR	IDENT	)	NUMBER
STATLIST	STATEMENT	DIGIT	1	2	3	4	5	6	7	8
	9	BLOCK	END							
STATEMENT	EXPR	EXPR-	TERM	TERM-	FACTOR	VAR	IDENT	)	NUMBER	DIGIT
	0	1	2	3	4	5	6	7	8	9
	9	BLOCK	END							
VAR	IDENT	TERM	TERM-	FACTOR	VAR	IDENT	)	NUMBER	DIGIT	0
EXPR	EXPR-	2	3	4	5	6	7	8	9	
	1	TERM	FACTOR	VAR	IDENT	)	NUMBER	DIGIT	0	1
EXPR-	TERM	3	4	5	6	7	8	9	0	1
	2	3	4	5	6	7	8	9	0	1
TERM	TERM-	FACTOR	JAR	IDENT	)	NUMBER	DIGIT	0	1	2
	3	4	5	6	7	8	9	0	1	2
TERM-	FACTOR	VAR	IDENT	)	NUMBER	DIGIT	0	1	2	3
	4	5	6	7	8	9	0	1	2	3
FACTOR	VAR	IDENT	)	NUMBER	DIGIT	0	1	2	3	4
	5	6	7	8	9	0	1	2	3	4
NUMBER	DIGIT	0	1	2	3	4	5	6	7	8
	9									
DIGIT	0	1	2	3	4	5	6	7	8	9

04

BLOCK	1	2	3	4	5	6	7	8	9	10	11	12	13	14	15	16	17	18	19	20	21	22	23	24	25	26	27	28	29	30	31	32	33	34	35	36	37	38		
BODY																																								
BODY-																																								
DECL																																								
STATLIST																																								
STATEMENT																																								
VAR																																								
EXPR																																								
EXPR-																																								
TERM																																								
TERM-																																								
FACTOR																																								
NUMBER																																								
DIGIT																																								
IDENT																																								
BEGIN																																								
END																																								
;																																								
←																																								
+																																								
-																																								
x																																								
/																																								
(																																								
)																																								
0																																								
1																																								
2																																								
3																																								
4																																								
5																																								
6																																								
7																																								
8																																								
9																																								
NEW																																								
↑																																								

SYNTAX IS A PRECEDENCE GRAMMAR

NO.	SYMBOL	F	G
001	BLUCK	003	004
002	BODY	001	001
003	BODY-	002	002
004	DECL	001	003
005	STATLIST	002	003
006	STATEMENT	003	003
007	VAR	006	004
008	EXPR	003	001
009	EXPR-	004	002
010	TERM	005	002
011	TERM-	005	003
012	FACTOR	006	003
013	NUMBER	006	004
014	DIGIT	008	006
015	IDENT	007	004
016	BEGIN	001	005
017	END	004	001
018	;	002	001
019	,	003	002
020	←	001	006
021	+	002	004
022	=	002	004
023	x	003	005
024	/	003	005
025	(	001	004
026	)	006	003
027	0	008	007
028	1	008	007
029	2	008	007
030	3	008	007
031	4	008	007
032	5	008	007
033	6	008	007
034	7	008	007
035	8	008	007
036	9	008	007
037	NEW	004	003
038	⊥	004	003

#### IV. EULER: An Extension and Generalization of ALGOL 60

In this chapter the algorithmic language EULER is described first informally and then formally by its syntax and semantics. An attempt has been made to generalize and extend some of the concepts of ALGOL thus creating a language which is simpler yet more flexible than ALGOL 60. A second objective in developing this language was to show that a useful programming language which can be processed with reasonable efficiency can be defined in rigorous formality.

##### A . An Informal Description of EULER:

###### 1. Variables and Constants

In ALGOL the following kinds of quantities are distinguished: simple variables, arrays, labels, switches and procedures. Some of these quantities 'possess values' and these values can be of certain types, integer, real and Boolean. These quantities are declared and named by identifiers in the head of blocks. Since these declarations fix some of the properties of the quantities involved, ALGOL is rather restrictive with respect to dynamic changes. The variables are the most flexible quantities, because values can be assigned dynamically to them. But the type of these values always remains the same. The other quantities are even less flexible. An array identifier will always designate a quantity with a fixed dimension, fixed subscript bounds and a fixed type of all elements. A procedure identifier will always designate a fixed procedure body, with a fixed number of parameters with fixed type specification (when given) and with fixed decision on whether the parameters are to be called by name or by value. A switch identifier always designates a list with a fixed number of fixed elements. We may call arrays, procedures, and switches 'semistatic',





EULER provides general type-test operators and some type conversion operators.

a) Numbers and Logical Constants

Numbers in EULER are essentially defined like unsigned numbers in ALGOL 60.

The logical constants are true and false.

b) References

A reference to a variable in EULER is a value of type Reference. It designates the identity of this particular variable rather than the value assigned to it. We can form a reference by applying the operator @ to a variable:

@<variable>

The inverse of the reference operator is the evaluation operator (.).

If a certain variable x has been assigned the reference to a variable y, then

x.

represents the variable y. Therefore the form

<variable>.

is also considered to be a variable.

c) Labels

A label is like in ALGOL a designation of an entry point into a statement sequence. It is a 'Program Reference'. A label is symbolically represented by an identifier. In contrast to ALGOL 60 each label has to be declared in the head of the block where it is defined. In the paragraph on declarations it is explained why this is so.

d) Symbols

A **symbol** (or character) in **EULER** is an **entity** denoted in a distinguishable manner as a literal **symbol**. A list of symbols is called a string.

e) Lists

Lists in EULER take the place of arrays in ALGOL. But they are more general than arrays in ALGOL in several respects. Lists can be assigned to variables, and are not restricted to a rectangular format; they can display a general tree structure. Furthermore, the structure of lists can be changed dynamically by list operators.

Basically a list is a linear array of a number of elements (possibly zero). A list element is a variable: to it can be assigned a constant of any type (in particular, it can itself be a list), and its identity can be specified by a reference.'

A list can be written explicitly as

(`<expression>` , `<expression>` , . . .)

The expressions are evaluated in sequence and the results are the elements of the created list.

A second way to specify a list literally is by means of the list operator list

list `<expression>`

where the expression has to deliver a value of type Number, and the result is a list with as many elements (initialized to  $\Omega$ ) as specified by the expression.

The elements of a list are numbered with the natural numbers beginning with 1. A list element can be referenced by subscripting

a variable (or a list element) to which a list is assigned. If the subscript is not an integer then its value rounded to the nearest integer is used for subscripting. An attempt to subscript with  $i$ , where  $i < 0$  or  $i > \text{length of the list}$ , results in an error indication. An example for specifying a list structure is

(1,2,(3,(4,5),6,())) .

This is a list with three elements, the first two elements being numbers, the third element being a list itself. This sublist has four elements, a number, another sublist, again a number and last another sublist with 0 elements. If this list would have been assigned to the variable  $a$ , then  $a[2]$  would be the number 2,  $a[3][2]$  would be the list (4,5) .

In order to manipulate lists, list operators are introduced into EULER. There are a type-test operator (isli), an operator to determine the current number of elements (length), a concatenation operator (&), and an operator to delete the first element of a list (tail). Here are some examples for the use of these operators:

(Assuming the list given above assigned to  $a$ )

<u>isli</u> $a[2]$	gives a value <u>false</u>
<u>length</u> $a[3][4]$	gives a value <u>0</u>
$(2,3) \& a[3][2]$	gives the list <u>(2,3,4,5)</u>
$(a[2]) \& \text{tail tail } a[3]$	gives the list <u>(2,6,())</u>

From the formal description of EULER it can be seen what rules have to be observed in applying list operators, and in what sequence these operators are executed when they appear together in an expression (like in the last example).

Only a minimal set of list operators is provided in EULER. This set can, however, easily be expanded. The introduction of list

manipulation facilities into EULER makes it possible to express with this language certain problems of processing symbolic expressions which can not be handled in ALGOL but required special list processing languages like LISP or IPL.

f) Procedures

Similar to ALGOL, a procedure is an expression which is defined once (possibly using formal parameters), and which can be evaluated at various places in the program (after substituting actual parameters). The notion of a procedure in EULER is, however, in several respects more general than in ALGOL. A procedure, i.e. the text representing it, is considered a constant, and can therefore be assigned to a variable. An evaluation of this variable effects an evaluation of this procedure, which always results in a value. In this respect every EULER procedure acts like a type-procedure in ALGOL. The number and type of parameters specified may vary from one call of a procedure to the next call of this same procedure.

Formally parameters are always called 'by value'. However, since an actual parameter can again be a procedure, the equivalent of a "call by name" in ALGOL can be accomplished. Furthermore an actual parameter being a reference establishes a third kind of call: "call by reference". It must be noted that the type of the call of a parameter is determined on the calling side. For example, assuming  $i = 1$  and  $a[i] = 2$ ,

$p(a[i])$	is a call by value,
$p('a[i]')$	is a call by procedure (name),
$p(@ a[i])$	is a call by reference.

In the first case the value of the parameter is 2, in the second case it is `a[i]`, in the third case it is the reference to `a[1]`.

A procedure is written as

‘<expression>’      or  
‘ $\delta$ ; $\delta$ ;...; $\delta$ ; <expression>’

where  $\delta$  represents a formal declaration. The evaluation of a procedure yields the expression enclosed in the quote marks.

A formal declaration is written as

formal <identifier> .

The scope of a formal variable is the procedure and the value assigned to it is the value of the actual parameter if there exists one,  $\Omega$  otherwise. When a formal variable is used in the body of the procedure, an evaluation of it is implied. For instance in

`p ← ‘formal x; x ← 5’; ...; p(@ a);`

the reference to `a` is assigned to the formal variable `x`, and the implied evaluation of `x` causes the number 5 to be assigned to the variable `a` (and not to the formal variable `x`). As a consequence, the call `p(1)` would imply that an assignment should be made to the constant 1. This is not allowed and will result in an error indication.

#### g) The Value ‘Undefined’

The constant  $\Omega$  means 'undefined?'. Variables are automatically initialized to this value by declarations. Also, a formal parameter is assigned this value when a procedure is called and no corresponding actual parameter is specified in the calling sequence.

## 2. Expressions

In ALGOL an expression is a rule for obtaining a value by applying certain operators to certain operands, which have themselves values. A statement in ALGOL is the basic unit to prescribe actions. In EULER these two entities are combined and called 'expression', while the term 'statement' is reserved for an expression which is possibly labelled. An expression in EULER, with the exception of a goto-expression, produces a value by applying certain operators to certain operands, and at the same time may cause side effects. The basic operands which enter into expressions are constants of the various types as presented in paragraph 1, variables and list elements, values read in from input devices, values delivered by the execution of procedures and values of expressions enclosed in brackets. Operators are in general defined selectively to operate on operands of a certain type and producing values of a certain type. Since the type of a value assigned to a variable can vary, type-tests have to be made by the operators at execution time. If a type test is unsuccessful, an error indication is given. Expressions are generally executed from left to right unless the hierarchy between operators demands execution in a different sequence. The hierarchy is implicitly given by the syntax.

Operators with the highest precedence are the following type test operators:

<u>isb</u>	<variable>	(is logical?)
<u>isn</u>	<variable>	(is number?)
<u>isr</u>	<variable>	(is reference?)
<u>isl</u>	.	(is label?)
<u>isy</u>	.	(is symbol?)
<u>isli</u>	.	(is list?)
<u>isp</u>	.	(is procedure?)
<u>isu</u>	<variable>	(is undefined?)

These operators, when applied to a variable, yield true or false, depending upon the type of the value currently assigned to the variable. At the same level are the numeric unary operators: abs (forming the absolute value of an operand of type Number), integer (rounding an operand of type Number to its nearest integer), the list reservation operator list, the length operator length (yielding the number of elements in a list), the tail operator, and type conversion operators like real, which converts a logical value into a number, logical which converts a number into a logical value, conversion operators from numbers to symbols and from symbols to numbers, etc.

The next lower precedence levels contain in this sequence: **Exponentiation** operator, multiplication operators ( $\times$ ,  $/$ ,  $\div$ , mod), addition operators (+, -), extremal operators (max, min). Operands and results are of type Number.

The next lower precedence levels contain the relational and logical operators in this sequence: relational operators ( $=$ ,  $\neq$ ,  $<$ ,  $\leq$ ,  $>$ ,  $\geq$ ), negation operator  $\neg$ , conjunction operator  $\wedge$ , disjunction operator  $\vee$ . The relational operators require that their operands are of type Number and they form a logical value. The operators  $\wedge$  and  $\vee$  are executed differently from their ALGOL counterparts: If the result is already determined by the value of the first operand, then the second operand is not evaluated at all. Thus, false  $\wedge$  x  $\rightarrow$  false, true  $\vee$  x  $\rightarrow$  true for all x.

The next lower precedence level contains the concatenation operator **&**.

Operators of the lowest level are the sequential operators goto,

If, then, and else, the assignment operator  $\leftarrow$ , the output operator out and the bracketing symbols begin and end. According to their occurrence we distinguish between the following types of expressions: goto-expression, assignment expression, output expression, conditional expression, and block. As it was already mentioned, all expressions except the goto-expression produce a value, while in addition they may or may not cause a side effect.

The go-to-expression is of the form

goto <expression>

If the value of the expression following the goto-operator is of the type Label, then control is transferred to the point in the program which this label represents. If this expression produces a value of a different type, then an error indication is given.

The assignment expression assigns a value to a variable. It is of the form

<variable>  $\leftarrow$  <expression>

In contrast to ALGOL an assignment expression produces a value, namely the value of the expression following the assignment operator, This general nature of the EULER assignment operator allows assignment of intermediate results of an expression. For example:

$a \leftarrow b + [c \leftarrow d + e]$

would compute  $d + e$ , assign this result to  $c$ , and then add  $b$ , and assign the total to  $a$ .

The output expression is of the form

out <expression>

The value of the expression following the output operator is transmitted



to an output medium . The value of the output expression is the value of the expression following the output operator.

A conditional expression is of the form

if <expression> then <expression> else <expression>

The meaning is the same as in ALGOL.

The construct

if <expression> then <expression>

is not allowed in EULER, because this expression would not produce a value, if the value of the first expression is false.

An expression can also be a block.

### 3. Statements and Blocks

A statement in EULER is an expression which may be preceded by one or more label definition'(s). If a statement is followed by another statement, then the two statements are separated by a semicolon. A semicolon discards the value produced by the previous statement. Since a goto-expression leads into the evaluation of a statement without encountering a semicolon, the goto operator also has to discard the value of the statement in which it appears.

A block in EULER is like in ALGOL a device to delineate the scope of identifiers used for variables and labels, and to group statements into statement sequences. A block is of the form

begin  $\sigma$ ;  $\sigma$ ; ...;  $\sigma$  end      or

begin  $\delta$ ;  $\delta$ ; ...;  $\delta$ ;  $\sigma$ ;  $\sigma$ ; ...;  $\sigma$  end

where  $\sigma$  represents a statement and  $\delta$  represents a declaration. The last statement of a block is not followed by a semicolon, therefore its value becomes the value of the block.

Since procedures, labels, and references in EULER are quantities which can be dynamically assigned to variables, there is a problem which is unknown to ALGOL: These quantities can be assigned to variables which in turn can be evaluated in places where these quantities or parts of them are undefined.

Situations like this are defined as semantic errors, i.e. the language definition is such that occurrences of these situations are detected.

#### 4. Declarations

There are two types of declarations in EULER, variable-declarations and label-declarations:

```
new <identifier>      and  
label <identifier>
```

A variable declaration defines a variable for this block and all inner blocks, to be referenced by this identifier as long as this same identifier is not used to redeclare a variable or a label in an inner block. A variable declaration also assigns the initial value  $\Omega$  to the variable. As discussed in paragraph 1, no fixed type is associated with a variable.

A label declaration serves a different purpose. It is not a definition like the variable declaration; it is only an announcement that there is going to be a definition of a label in this block of the form

```
<identifier> :
```

prefixing a statement.

Although the label declaration is dispensable it is introduced into EULER to make it easier to handle forward references. A situation like

```
begin...L:...begin...goto L;...L:...end;..end
```

makes it necessary to detect that the identifier L following the goto operator is supposed to designate the label defined in the inner block. Without label declarations it is impossible to decide, whether an identifier (not declared in the same block) refers to a variable declared in an outer block, or to a label to be defined later in this block, unless the whole block is scanned. With a label declaration every identifier is known upon encounter.

## B. The Formal Definition of EULER

EULER was to be a language which can be concisely defined in such a way that the language is guaranteed to be unambiguous, and that from the language definition a processing system can be derived mechanically, with the additional requirement that this processing system should run with reasonable efficiency. A method to perform this transformation mechanically, and to accomplish parsing efficiently, has been developed and is given in Chapter III for languages which are simple precedence phrase structure languages. Therefore, it appeared to be highly desirable to define EULER as a simple precedence language with precedence functions. It was possible to do this and still include in EULER the main features of ALGOL and generalize and extend ALGOL as described.

The definition of EULER is given in two 'steps' to insure that the language definition itself forms a reasonably efficient processing system for EULER texts. The definition of the compiling system consists of the parsing algorithm, given in paragraph III.B.1., a set of syntactic rules, and a set of corresponding interpretation rules by which an EULER text is transformed into a polish string. The definition of the executing system consists of a basic interpreting mechanism with a rule to interpret each symbol in the polish string. Both descriptions use the basic notation of chapter II. If the definition of EULER would have been given in one step like the definition of the example in chapter III C, it would have been necessary to transform it into a two phase system in order to obtain an efficient processing system. Furthermore, a one phase definition requires the introduction of certain concepts (e.g. a passive mode, where a text is only parsed but not evaluated) which are without consequence for

practical systems, because they take on an entirely different appearance when transformed into a two phase system.

The form of the syntactic definition of EULER is influenced by the requirement that EULER be an unambiguous simple precedence phrase structure language. This involves that:

- a) there must be exactly one interpretation rule (possibly empty) for each syntactic rule,
- b) the parsing algorithm has to find reducible substrings in exactly the same sequence in which the corresponding interpretation rules have to be obeyed,
- c) extra syntactic classes (with empty interpretation rules) have to be introduced to insure that at most one precedence relation holds between any two symbols,
- d) no two syntactic rules can have the same right part.

For an illustration of the requirements a) and b) consider the syntactic definition of an arithmetic expression in ALGOL 60:

```
<arithmetic expression> ::= <simple arithmetic expression> |  
    <if clause> <simple arithmetic expression> else  
    <arithmetic expression>
```

If the text

```
    if b then a + c else d + e
```

is parsed, then  $d + e$  is reduced to `<arithmetic expression>` and accordingly evaluated, before it has been taken into account that the preceding `<if clause>` may prevent  $d + e$  to be evaluated at all. In this example, the syntax of ALGOL 60 fails to reflect the sequence of evaluation properly, as it does e.g. in the formulations of simple expressions.

To correct this default, the corresponding syntactic definitions in EULER are as follows: (BNF is adopted here to obviate the analogies)

```

<expresssion> ::= <if clause> <>true part> <expression>
<if clause> ::= if <expression> then'
<true part> ::= <expression> else

```

In the example above, the operator else will be recognized as occurring in <true part> before the expression  $d + e$  is parsed. Through the interpretation rule for <true part> the necessary code can be generated.

A similar situation holds for the ALGOL definition

```

<basic statement> ::= <label> : <basic statement>

```

The colon, denoting the definition of a label, is included in a reduction only after <basic statement> was parsed and evaluated. In EULER the corresponding definitions read:

```

<statement> ::= <label definition> <statement>
<label definition> ::= <identifier> :

```

Thus the parsing algorithm detects the label definition before parsing the statement.

- As a third example, we give the EULER definition of <disjunction>

```

<disjunction> ::= <disjunction head> <disjunction>
<disjunction head> ::= <conjunction> V

```

Thus,  $\vee$  is included in a syntactic reduction, before <disjunction> is parsed and evaluated; code can be generated which allows conditional skipping of the following part of program corresponding to <disjunction>.

The corresponding ALGOL syntax

```

<Boolean term> ::= <Boolean term> V <Boolean factor>

```

reflects the fact that both <Boolean term> and <Boolean factor> are to be evaluated before the logical operation is performed. This interpretation of the logical operators  $\wedge$  and  $\vee$  was deliberately discarded as being undesirable.

According to requirement c) the language definition of EULER contains certain auxiliary nonbasic symbols like



designates a label (defined or undefined at this time). Therefore, a label is inserted into the polish string instead of a variable.

A second example for the specific arrangement of the syntax chosen to fulfill requirement d) is the following: The concatenation operator (&) is introduced into the syntax in the syntactic class <catena>, which is defined as

$$\langle \text{catena} \rangle ::= \langle \text{catena} \rangle \& \langle \text{primary} \rangle \mid \langle \text{disjunction} \rangle$$

This looks as if & had a lower precedence than the logical and arithmetic operators. But this is of no consequence, since an operand of & must be a quantity of type List and a <disjunction> can only be of type List if it is a <primary>, i.e. not containing any logical or arithmetic operators.

- But we cannot write

$$\langle \text{catena} \rangle ::= \langle \text{primary} \rangle ,$$

because this would violate requirement d). Therefore <catena> appears in the syntax at a rather arbitrary place between <primary> and <expression>.

Looking at the requirements made upon the language definition and observing the careful choices that had to be made in drawing up the language definition in line-with these requirements, the criticism will probably be raised, that the difficulties usually encountered in deriving syntax directed compilers for given languages are not avoided in EULER but merely 'sneaked' into the definition of the language itself. This point is well taken, but we think that nobody is likely to create something as complicated as a processing system for an algorithmic language like ALGOL without encountering some difficulties somewhere. We think



it is the merit of this method of language definition to bring these difficulties into the open, so that the basic concepts involved can be recognized and systematically dealt with. It is no longer possible to draft an 'ad hoc syntax' and call it a programming language, because the natural relationship between structure and meaning must be established.

Subsequently follows the formal definition of EULER. It has been programmed as an Extended ALGOL program for the Burroughs B5500 computer. This program is listed in Appendix II.

Phase I (Translator)

The vocabulary  $\mathcal{V}$ :

The set of basic symbols  $\mathcal{B}$ : \*

0|1|2|3|4|5|6|7|8|9|,|.|;|:|@|new|formal|label| $\lambda$ |[|]|begin|end|  
(|)|'|'|goto|out| $\leftarrow$ |if|then|else|&| $\vee$ | $\wedge$ | $\neg$ |= $\neq$ |<| $\leq$ | $\geq$ |>|  
min|max|+|-| $\times$ |/| $\div$ |mod| $\uparrow$ |abs|length|integer|real|logical|  
list|tail|in|isb|isn|isr|isl|isli|isy|isp|isu| $\sigma$ | $\Omega$ |  
to|:-|true|false| $\perp$

The set of non-basic symbols  $\mathcal{V} - \mathcal{B}$ :

program|block|blokhead|blokbody|labdef|stat|stat-|  
expr|expr-|ifclause|truepart|catena|disj|disjhead|  
conj|conj-|conjhead|negation|relation|choice|choice-|  
sum|sum-|term|term-|factor|factor-|primary|procdef|  
prothead|list\*|reference|number|real\*|  
integer\*|integer-|digit|logval|var|var-|vardecl|  
labdecl|fordecl

The environment  $\mathcal{E}_1$ :

S (stack used by the parsing algorithm)  
V  
i (index to S and V)  
j (index to S and V)  
P (program produced by Phase I)  
k (index to P)  
N (list of identifiers and associated data)  
n (index to N)  
m (index to N)  
bn (block number)  
on (ordinal number)  
scale (scale factor for integers)

$\mathcal{E}_1 = \langle S, V, i, j, P, k, N, n, m, bn, on, scale \rangle$

\*  $\lambda$  and  $\sigma$  are representatives for identifiers and symbols respectively.

1: <u>vardecl</u> → <u>new</u> $\lambda$	$k \leftarrow k+1; P[k] \leftarrow ('new');$ $n \leftarrow n+1; N[n] \leftarrow (V[i], bn, on, 'new');$
2: <u>fordecl</u> → <u>formal</u> $\lambda$	$k \leftarrow k+1; P[k] \leftarrow ('formal');$ $n \leftarrow n+1; N[n] \leftarrow (V[i], bn, on, 'formal');$
3: <u>labdecl</u> → <u>label</u> $\lambda$	$n \leftarrow n+1; N[n] \leftarrow (V[i], bn, \Omega, \Omega)$
4: <u>var-</u> → $\lambda$	$t \leftarrow tn; k \leftarrow k+1;$ L41: <u>if</u> $t < 1$ <u>then goto</u> Error; <u>if</u> $N[t][1] = V[i]$ <u>then goto</u> L42; $t \leftarrow t-1;$ <u>goto</u> L41; L42: <u>if</u> $N[t][4] \neq 'new'$ <u>then goto</u> L43; $P[k] \leftarrow (@, N[t][3], N[t][2]);$ <u>goto</u> L46 L43: <u>if</u> $N[t][4] \neq 'label'$ <u>then goto</u> L44; $P[k] \leftarrow ('label', N[t][3], N[t][2]);$ <u>goto</u> L46 L44: <u>if</u> $N[t][4] \neq 'formal'$ <u>then goto</u> L45; $P[k] \leftarrow (@, N[t][3], N[t][2]);$ $k \leftarrow k+1; P[k] \leftarrow ('value');$ <u>goto</u> L46 L45: $P[k] \leftarrow ('label', N[t][3], N[t][2]);$ $N[t][3] \leftarrow t-k;$ <u>goto</u> L46; L46:
5: <u>var-</u> → [ <u>expr</u> ] _____	$k \leftarrow k+1; P[k] \leftarrow ('')$
6: <u>var-</u> → <u>var-</u> .	$k \leftarrow k+1; P[k] \leftarrow ('value')$
7: <u>var</u> . → <u>var-</u>	$\wedge$
8: <u>logval</u> → <u>true</u>	$V[j] \leftarrow true$
9: <u>logval</u> → <u>false</u>	$V[j] \leftarrow false$
10: <u>digit</u> 4 0 .....	$V[j] \leftarrow 0$ .....
19: <u>digit</u> 9	$V[j] \leftarrow 9$
20: <u>integer-</u> → <u>digit</u>	$scale \leftarrow -1$
21: <u>integer-</u> + <u>integer-</u> <u>digit</u>	$t \leftarrow 10 \times V[j]; V[j] \leftarrow V[i] + t;$ $scale \leftarrow scale - 1$
22: <u>integer*</u> 3 <u>integer-</u> .	$\wedge$
23: <u>real*</u> → <u>integer*</u> . <u>integer*</u>	$t \leftarrow 10 \uparrow scale;$ $t \leftarrow V[i] \times t;$ $V[j] \leftarrow V[j] + t$
24: <u>real*</u> 3 <u>integer*</u>	$\wedge$

25: <u>number</u>	→ <u>real*</u>	^
26: <u>number</u>	→ <u>real*</u> 10 <u>integer*</u>	t ← 10 ↑ V[i]; V[j] ← V[j] × t
27: <u>number</u>	→ 10 <u>integer*</u>	t ← 0.1 ↑ V[i]; V[j] ← V[j] × t
28: <u>number</u>	→ 10 <u>integer*</u>	V[j] ← 10 ↑ V[i]
29: <u>number</u>	→ 10 <u>integer*</u>	V[j] ← 0.1 ↑ V[i]
30: <u>reference</u>	→ @ <u>var</u>	^
31: <u>listhead</u>	→ <u>listhead expr</u> ,	V[j] ← V[j] + 1
32: <u>listhead</u>	→ (	V[j] ← 0
33: <u>list*</u>	→ <u>listhead expr</u> )	k ← k+1; P[k] ← ('', V[j] + 1)
34: <u>list*</u>	→ <u>listhead</u> )	k ← k+1; P[k] ← ('', V[j])
35: <u>prothead</u>	→ <u>prothead fordecl</u> ;	^
36: <u>prothead</u>	→ ‘	bn ← bn+1; on ← 0; k ← k+1; P[k] ← ('', Ω); V[j] tk; n ← n+1; N[n] ← (Ω, m); m t n
37: <u>procdef</u>	→ <u>prothead expr</u> ’	k ← k+1; P[k] ← (''); P[V[j][2] ← k+1; bn tbn - 1; n tm-1; m ← N[m][2]
38: <u>primary</u>	→ var	k ← k+1; P[k] ← ('value')
39: <u>primary</u>	→ var <u>list*</u>	k ← k+1; P[k] ← ('call')
40: <u>primary</u>	→ <u>logval</u>	k ← k+1; P[k] ← ('logval', V[j])
41: <u>primary</u>	→ <u>number</u>	k ← k+1; P[k] ← ('number', V[j])
42: <u>primary</u>	→ σ	k ← k+1; P[k] ← ('symbol', V[j])
43: <u>primary</u>	→ <u>reference</u>	A
44: <u>primary</u>	→ <u>list*</u>	A
45: <u>primary</u>	→ <u>tail primary</u>	k ← k+1; P[k] ← ('tail')
46: <u>primary</u>	→ <u>procdef</u>	A
47: <u>primary</u>	→ Ω	k ← k+1; P[k] ← ('Ω')

48:	<u>primary</u>	→ [ <u>expr 1</u>	∧
49:	<u>primary</u>	→ <u>in</u>	k ← k+1; P[k] ← ('in')
50:	<u>primary</u>	→ <u>isn var</u>	k ← k+1; P[k] ← (' <u>isb</u> ')
51:	<u>primary</u>	→ <u>isn var</u>	k ← k+1; P[k] ← (' <u>isn</u> ')
52:	<u>primary</u>	→ <u>isr var</u>	k ← k+1; P[k] ← (' <u>isr</u> ')
53:	<u>primary</u>	→ <u>isl var</u>	k ← k+1; P[k] ← (' <u>isl</u> ')
54:	<u>primary</u>	+ <u>isli var</u>	k ← k+1; P[k] ← (' <u>isli</u> ')
55:	<u>primary</u>	→ <u>isy var</u>	k ← k+1; P[k] ← (' <u>isy</u> ')
56:	<u>primary</u>	→ <u>isp var</u>	k ← k+1; P[k] ← (' <u>isp</u> ')
57:	<u>primary</u>	→ <u>isn var</u>	k ← k+1; P[k] ← (' <u>isn</u> ')
58:	<u>primary</u>	→ <u>abs primary</u>	k ← k+1; P[k] ← (' <u>abs</u> ')
59:	<u>primary</u>	→ <u>length var</u>	k ← k+1; P[k] ← (' <u>length</u> ')
60:	<u>primary</u>	→ <u>integer primary</u>	k ← k+1; P[k] ← (' <u>integer</u> ')
61:	<u>primary</u>	→ <u>real primary</u>	k ← k+1; P[k] ← (' <u>real</u> ')
62:	<u>primary</u>	→ <u>logical primary</u>	k ← k+1; P[k] ← (' <u>logical</u> ')
63:	<u>primary</u>	→ <u>list primary</u>	k ← k+1; P[k] ← (' <u>list</u> ')
64:	<u>factor-</u>	→ <u>primary</u>	∧
65:	<u>factor-</u>	→ <u>factor-</u> ↑ <u>primary</u>	k ← k+1; P[k] ← ('↑')
66:	<u>factor</u>	→ <u>factor-</u>	∧
67:	<u>term-</u>	→ <u>factor</u>	∧
68:	<u>term-</u>	→ <u>term-</u> × <u>factor</u>	k ← k+1; P[k] ← ('×')
69:	<u>term-</u>	→ <u>term-</u> / <u>factor</u>	k ← k+1; P[k] ← ('/')
70:	<u>term-</u>	→ <u>term-</u> ÷ <u>factor</u>	k ← k+1; P[k] ← ('÷')
71:	<u>term-</u>	→ <u>term-</u> mod <u>factor</u>	k ← k+1; P[k] ← (' <u>mod</u> ')
72:	<u>term</u>	→ <u>term-</u>	∧
73:	<u>sum-</u>	→ <u>term</u>	∧

74: sum- ++ term  $\wedge$

75: sum- --term  $k \leftarrow k+1; P[k] \leftarrow ('-')$

76: sum-  $\rightarrow$  sum- + term  $k \leftarrow k+1; P[k] \leftarrow ('+')$

77: sum-  $\rightarrow$  sum- -term  $k \leftarrow k+1; P[k] \leftarrow ('-')$

78: sum  $\rightarrow$  sum-  $\wedge$

79: choice- + sum  $\wedge$

80: choice-  $\rightarrow$  choice- min sum  $k \leftarrow k+1; P[k] \leftarrow ('min')$

81: choice-  $\rightarrow$  choice- max sum  $k \leftarrow k+1; P[k] \leftarrow ('max')$

82: choice  $\rightarrow$  choice-  $\wedge$

83: relation  $\rightarrow$  choice  $\wedge$

84: relation  $\rightarrow$  choice = choice  $k \leftarrow k+1; P[k] \leftarrow ('=')$

85: relation  $\rightarrow$  choice  $\neq$  choice  $k \leftarrow k+1; P[k] \leftarrow ('\neq')$

86: relation  $\rightarrow$  choice < choice  $k \leftarrow k+1; P[k] \leftarrow ('<')$

87: relation  $\rightarrow$  choice  $\leq$  choice  $k \leftarrow k+1; P[k] \leftarrow ('\leq')$

88: relation  $\rightarrow$  choice  $\geq$  choice  $k \leftarrow k+1; P[k] \leftarrow ('\geq')$

89: relation  $\rightarrow$  choice > choice  $k \leftarrow k+1; P[k] \leftarrow ('>')$

90: negation  $\rightarrow$  relation  $\wedge$

91: negation  $\rightarrow$   $\neg$  relation  $k \leftarrow k+1; P[k] \leftarrow ('\neg')$

92: conjhead  $\rightarrow$  negation  $\wedge$   $k \leftarrow k+1; P[k] \leftarrow ('A', \Omega); V[j] \leftarrow k$

93: conj-  $\rightarrow$  conjhead conj  $P[V[j]][2] \leftarrow k+1$

94: conj-  $\rightarrow$  negation  $\wedge$

95: conj  $\rightarrow$  conj-  $\wedge$

96: disjhead  $\rightarrow$  conj  $\vee$   $k \leftarrow k+1; P[k] \leftarrow ('V', \Omega); V[j] \leftarrow k$

97: disj  $\rightarrow$  disjhead disj  $P[V[j]][2] \leftarrow k+1$

98: disj  $\rightarrow$  conj  $\wedge$

99: catena 3 catena & primary  $k \leftarrow k+1; P[k] \leftarrow ('&')$

100:	<u>catena</u>	→ <u>disj</u>	∧
101:	<u>truepart</u>	3 <u>expr</u> <u>else</u>	$k \leftarrow k+1; P[k] \leftarrow ('else', \Omega); V[j] \leftarrow k$
102:	<u>ifclause</u>	→ <u>if</u> <u>expr</u> <u>then</u>	$k \leftarrow k+1; P[k] \leftarrow ('then', \Omega); V[j] \leftarrow k$
103:	<u>expr-</u>	→ <u>'Block</u>	∧
104:	<u>expr-</u>	→ <u>ifclause</u> <u>truepart</u> <u>expr-</u>	$P[V[j]][2] \leftarrow V[j+1] + 1; P[V[j+1]][2] \leftarrow k+1$
105:	<u>expr-</u>	→ <u>var</u> ← <u>expr-</u>	$k \leftarrow k+1; P[k] \leftarrow ('t')$
106:	<u>expr-</u>	→ <u>goto</u> <u>m a r y</u>	$k \leftarrow k+1; P[k] \leftarrow ('goto')$
107:	<u>expr-</u>	→ <u>out</u> <u>expr-</u>	$k \leftarrow k+1; P[k] \leftarrow ('out')$
108:	<u>expr-</u>	→ <u>catena</u>	∧
109:	<u>expr</u>	→ <u>expr-</u>	∧
110:	<u>stat-</u>	→ <u>labdef</u> <u>stat-</u>	∧
111:	<u>stat-</u>	→ <u>expr</u>	∧
112:	<u>stat</u>	→ <u>stat-</u>	∧
113:	<u>labdef</u>	→ $\lambda :$	$t \ t \ n ;$ L1131: <u>if</u> $t \leq m$ <u>then</u> <u>goto</u> <u>ERROR</u> ; <u>if</u> $N[t][1] = V[j]$ <u>then</u> <u>goto</u> L1132; $t \leftarrow t-1$ ; <u>goto</u> L1131; L1132: <u>if</u> $N[t][4] \neq \Omega$ <u>then</u> <u>goto</u> <u>ERROR</u> ; $s \leftarrow N[t][3]$ ; $N[t][3] \leftarrow k+1$ ; $N[t][4] \leftarrow 'label'$ ; L 1133: <u>if</u> $s = \Omega$ <u>then</u> <u>goto</u> L1134; $t \leftarrow P[s][2]$ ; $P[s][2] \leftarrow k+1$ ; $s \leftarrow t$ ; <u>goto</u> L1133; L1134:
114:	<u>blockhead</u>	→ <u>begin</u>	$bn \leftarrow bn+1; on \leftarrow 0; k \leftarrow k+1$ ; $P[k] \leftarrow ('begin')$ ; $n \leftarrow n+1; N[n] \leftarrow (\Omega, m); m \leftarrow n$
115:	<u>blokhead</u>	→ <u>blokhead</u> <u>vardecl</u> ;	∧
116:	<u>blokhead</u>	→ <u>blokhead</u> <u>labdecl</u> ;	∧
117:	<u>blokbody</u>	→ <u>blokhead</u> . .	∧
118:	<u>blokbody</u>	→ <u>blokbody</u> <u>stat</u> ;	$k \leftarrow k+1; P[k] \leftarrow (';')$
119:	<u>block</u>	→ <u>blokbody</u> <u>stat</u> <u>end</u>	$k \leftarrow k+1; P[k] \leftarrow ('end')$ ; $bn \ t m-1; m \leftarrow N[m][2]$
120:	<u>program</u>	→ $\perp$ <u>block</u> $\perp$	∧

## Phase II (Interpreter)

The following is the definition of the execution code produced by Phase I.

The variables involved are:

S (tree structured memory stack)  
i (stack index)  
mp (stack index, points at the last  
element of a linked list of Marks)  
P (program)  
k (program index of the instruction  
currently being interpreted)  
fct (counter of formal parameters)

s , t , A , B , C (variables and labels local to any interpretation  
rule)

$$\mathcal{E}_2 = \{ S , i , mp , P , k , fct \}$$

The following types of quantities are introduced, which were not mentioned in Chapter II :

labels (i.e. program references)  
procedures (i.e. procedure descriptors)

with the accompanying type-test operators isl, isp and the following type-conversion operators :

progref converting the two integers pa and bn into the program-reference with address pa defined in the block with number bn.

proc converting three integers (block-number, Mark-index, program-address) into a uniquely defined procedure-descriptor,

bln converting a procedure-descriptor into its block-number,

mix converting a procedure-descriptor or a label into the index of the Mark belonging to the block in which the procedure-descriptor or label is defined (Mark-index),



adr converting a procedure-descriptor or a label into its program address.

Also, there exists an operator

reference converting the two integers  $on$  and  $bn$ , into the reference of the variable with ordinal number  $on$  in the variable-list of the block with number  $bn$ .

The detailed description of these operators depends on the particular scheme of referencing used in an implementation, for which an example is given in Appendix II. It should be noted, however, that a reference, label or procedure-descriptor, may become undefined if it is assigned to any variable which is not in its scope. Since procedures and blocks may be activated recursively, the actual identity of a reference, label or procedure-descriptor can only be established in Phase II, which makes it necessary for Phase I to describe them in terms of more than one quantity. The sufficient and necessary amount of information to establish these identities is contained in the 'Marks' stored in  $S$ . Marks are created upon entry into a block (or procedure) and deleted upon exit.

A Mark contains the following data:

1. a block-number
2. a link to its dynamically enclosing block
3. a link to its statically enclosing block
4. a list of its variables
- 5: a program return address

By 'link' is meant the index of the Mark of the indicated block. —

The following list indicates to the left the operator  $P[k][l]$  currently to be executed, and to the right the corresponding interpretation algorithm. At the end of each rule a transfer to the Cycle routine has to be implicitly understood. This basic fetch cycle is represented as follows:

```

Initialize:  i ← 0; mp ← 0; k ← 0;
Cycle      :  k ← k+1;
T          :  Obey the Rule designated
              by P[k][1]; goto Cycle

```

Operators Interpretation Rules ( $\Psi_2$ )

```

+          if  $\neg$  isn S[i-1] then goto ERROR;
          if  $\neg$  isn S[i] then goto ERROR;
          S[i-1] ← S[i-1] + S[i]; i ← i-1

```

```

-
x
/
+
mod
} defined analogously to +

```

```

·          if  $\neg$  isn S[i] then goto ERROR;
          S[i] ← - S[i]

```

```

abs
integer
logical
} defined analogously to :

```

```

real          if  $\neg$  isb S[i] then goto ERROR;
                S[i] ← real S[i]

```

```

min          if  $\neg$  isn S[i-1] then goto ERROR;
                if  $\neg$  isn S[i] then goto ERROR;
                i ← i-1;
                if S[i] < S[i+1] then goto A;
                S[i] ← S[i+1]; A:

```

```

max          defined analogously to min

```

```

isn          if  $\neg$  isr S[i] then goto A;
                S[i] ← S[i]. ;
                A: S[i] ← isn S[i]

```

```

isb
isr
isl
isli
isy
isp
isu
} defined analogously to isn

```

```

<      if  $\neg$  isn S[i-1] then goto ERROR;
      if  $\neg$  isn S[i] then goto ERROR;
      S[i-1]  $\leftarrow$  S[i-1] < S[i]; it i-1

<
>
=
/
^      if  $\neg$  isb S[i] then goto ERROR;
      if S[i] then goto A;
      k  $\leftarrow$  P[k][2]; goto T;
      A: i - i - 1

V      if  $\neg$  isb S[i] then goto ERROR;
      if  $\neg$  S[i] then goto A;
      k  $\leftarrow$  P[k][2]; goto T;
      A: i  $\leftarrow$  i - 1

1      if  $\neg$  isb S[i] then goto ERROR;
      S[i]  $\leftarrow$   $\neg$  S[i] ----

then   if  $\neg$  isb S[i] then goto ERROR;
        i  $\leftarrow$  i - 1;
        if S[i+1] then goto A;
        k  $\leftarrow$  P[k][2]; goto T ;
        A:

else   k  $\leftarrow$  P[k][2]; goto T

length if  $\neg$  isr S[i] then goto A;
        S[i]  $\leftarrow$  S[i].;
        A: if  $\neg$  isli S[i] then goto ERROR;
        S[i]  $\leftarrow$  length S[i]

tail   if  $\neg$  isli S[i] then goto ERROR;
        S[i]  $\leftarrow$  tail S[i]

&        if  $\neg$  isli S[i-1] then goto A;
        if  $\neg$  isli S[i] then goto ERROR;
        S[i-1]  $\leftarrow$  S[i-1] & S[i]; i  $\leftarrow$  i - 1

list   A: if  $\neg$  isn S[i] then goto ERROR;
        t  $\leftarrow$  S[i]; S[i]  $\leftarrow$  ();
        B: if t  $\leq$  0 then goto C;
        S[i]  $\leftarrow$  S[i] & ( $\Omega$ ); t  $\leftarrow$  t - 1;
        goto B; C:

```

```

number      i ← i+1; S[i] ← P[k][2]
logval     i ← i+1; S[i] ← P[k][2]
Ω            i ← i+1; S[i] ← Ω
string     i ← i+1; S[i] ← P[k][2]
label      i ← i+1; S[i] ← progref(P[k][2], P[k][3])
@           i ← i+1; S[i] ← reference(P[k][2], P[k][3])
new        S[mp][4] ← S[mp][4] & (Ω)
formal     fct ← fct+1;
             if fct < length S[mp][4] then goto A;
             S[mp][4] ← S[mp][4] & (Ω); A:
←           if ¬ isr S[i-1] then goto ERROR;
             S[i-1]. ← S[i]; S[i-1] ← S[i]
             i ← i-1;

             i ← i - 1

             if ¬ isn S[i] then goto ERROR;
             if S[i] ≤ 0 then goto ERROR; i ti-1;
             if ¬ isr S[i] then goto ERROR;
             S[i] ← S[i].;
             if ¬ isli S[i] then goto ERROR;
             t ← length S[i];
             if S[i+1] > t then goto R ;
             S[i] ← @ S[i][S[i+1]]
                                     (subscript)

begin       i ← i+1;
             S[i] ← (S[mp][1]+1, mp, mp, ());
             mp ← i
                                     (a Mark)

end        t ← S[mp][2]; S[mp] ← S[i];
             itmp; mp ← t

‘         i ← i+1;
             S[i] ← proc (S[mp][1]+1, S[mp][3], k)
             k ← P[k][2]; goto T

value     if ¬ isr S[i] then goto A;
             S[i] ← S[i].;
             A: if ¬ isp S[i] then goto B;
             fct ← 0; t ← S[i];
             S[i] ← (bln t, mix t, mp, ( ), k);
             mp ← i; k ← adr t; B:
                                     (a Mark)

```

```

call      i ← i-1;
            if 1 isr S[i] then goto A;
            S[i] ← S[i].;
            A: if lisp S[i] then goto ERROR;
            fct ← 0; t ← S[i];
            S[i] ← (bln t, mix t, mp, S[i+1], k);
            mp ti; k ← adr t
            (a Mark)

            ,
            k ← S[mp][5]; t ← S[mp][2];
            S[mp] ← S[i];
            itmp; mp ← t

got0      if ¬ isl S[i] then goto ERROR;
            mp ← mix S[i]; pp ← adr S[i];
            i ← mp; goto T

            )·
            t ← P[k][2]; s ← ()
            A: if t = 0 then goto B;
            t ← t-1; s ← s & (S[i-t]); goto A;
            B: i ← i+1; i ← i - P[k][2];
            S[i] ← s
            (build a list)

```

Certain features of ALGOL are not included in EULER, because they were thought to be non basic (or not necessary), or because they did not fit easily into the EULER definition, or both.

Examples are

the empty statement, allowing an extra semicolon before end,  
the declaration list, avoiding the necessity of repeating the declarator in front of each identifier,  
the conditional statement without else,  
the for-statement,  
the own type.

It is felt that these features could be included in a somewhat 'fancier' EULER+ language, which is transformed into EULER by a prepass to the EULER processing system. This prepass might include other features - like 'macros' or 'clichés', it would take care of the proper deletion of comments, etc. Certain standard macros or procedures might be known to this prepass and could thus be used in EULER+ without having been declared, like the standard functions in ALGOL. The set of these procedures would necessarily have to include a complete set of practical input-output procedures. It should be noted, however, that in contrast to ALGOL, they can be described in EULER itself, assuming the existence of appropriate operators in and both (~~reading and editing characters~~) of symbols and lists (formats are lists of symbols), of type-test- and conversion-operators are of course instrumental in the design of these procedures. A few other useful 'standard procedures' are given as programming examples in the following paragraph. (cf. 'for', 'equal' and 'array')

### C. Examples of Programs

A list can contain elements of various types, here numbers and procedures:

```
begin new x; new s;  
  s ← (2, 'begin x ← x+1; s[x] end', 'out x') x ← s[1]; s[x]  
end
```

\* \* \* \* \*

A reference can be used to designate a sublist. Thus repeated double indexing is avoided:

```
begin new a; new r;  
  a ← (1, (2,3),4); The output is: 2, 3  
  r ← @a[2];  
  out r.[1]; out r.[2];  
  r.[1] ← Ω  
end
```

\* \* \* \* \*

A procedure assigned to a variable (here p) is replaced by a constant, as soon as further execution of the test  $n < 100$  is no longer needed:

```
begin new p; new n; new f;  
  n ← 0;  
  p ← 'n ← n+1; if n < 100 then f(n) else p ← f(n)';  
  f ← 'formal x; .....';  
  .....  
end
```

\* \* \* \* \*

If a parameter is a 'value-parameter', the value is established at call time. In the case of a 'name-parameter', no evaluation takes place at call time. Thus the output of the following program is 4,16,3

```

begin new p; new a; new i;
  p ← 'formal x; formal k;
    begin k ← k+1; out x end';
  i ← 1;
  a ← (4, 9,16);
  p(a[i], @i); p('a[i]', @i); out i
end

```

```

begin new p; new a; new i;
  p ← 'formal x; formal k;
    begin k ← k+1; x ← k end';
  a ← list 3; i ← 1;
  p(@a[i], @i); p('@a[i]', @i)
end

```

Here the final value of a is (2, Ω,3).

\* \* \* \* \* S t \* \* \* \* \*

A for statement is not provided in EULER. It can, however, easily be programmed as a procedure and adapted to the particular needs. Two examples are given below, the latter corresponding to the ALGOL for:

```

for ← 'formal v; formal n; formal s;
  begin label k; v ← 1;
    k: if v ≤ n then
      begin s; v ← v+1; goto k end
    else Ω
  end'
algolfor ← 'formal v; formal l; formal step; formal u; formal s;
  begin label k; v ← l;
    k: if (v-u) × step ≤ 0 then
      begin s; v ← v + step; goto k end
    else Ω
  end'

```



It should be noted that the decision whether the iterated statement should be able to alter the values of the increment and limit is made in each call for 'for' individually by either enclosing the actual parameters in quotes (name-parameter), or omitting the quotes (value-parameter).

E.g. a)  $n \leftarrow 5$ ; for (@i, n, 'begin n  $\leftarrow$  n-1; out n end')  
 b)  $n \leftarrow 5$ ; for (@i, 'n', 'begin n  $\leftarrow$  n-1; out n end')  
 .....

a) yields 4,3,2,1,0, while b) yields 4,3,2 .

\* \* \* \* \*

There is no provision for an operator comparing lists in EULER. But list comparisons can easily be programmed. The given example uses the 'for' defined above:

```

equal  $\leftarrow$  'formal x; formal y;
  begin new t; new i; label k;
    t  $\leftarrow$  false;
    if isli x  $\wedge$  isli y  $\wedge$  length x = length y then
      begin for (@i, length x,
        'if  $\neg$ equal (@x[i], @y[i]) then goto k else  $\Omega$ ');
        t ttrue
      end else
        t tisn x  $\wedge$  isn y  $\wedge$  x=y;
      k: t
    end'

```

It should be noted that the definition of A deviates from ALGOL and thus makes this program possible; therefore in

t tisn x  $\wedge$  isn y  $\wedge$  x=y

the relation x=y is never evaluated if either x or y is a number.

If the list elements may also be logical values or symbols, then the above statement must be expanded into:

$t \leftarrow \text{isn } x \wedge \text{isn } y \wedge x=y \vee \text{isb } x \wedge \text{isb } y \wedge \text{real } x = \text{real } y \vee$   
 $\text{isy } x \wedge \text{isy } y \wedge \text{real } x = \text{real } y$

\*\*\*\*\*

There is no direct provision for an array declaration (or rather array 'reservation') either. It can be programmed by the following procedure:

```

array ← 'formal l; formal x;
begin new t; new a; new b; new i;
  b ← l; t ← list b[1];
  a ← if length b > 1 then array (tail b, x) else x;
  for (@i, b[1], 't[i] ← a');
  t
end'

```

The statement  $a \leftarrow \text{array} ((x_1, x_2, \dots, x_n))$  would then correspond to the ALGOL array declaration

array a[1: x<sub>1</sub>, 1: x<sub>2</sub>, . . . , 1: x<sub>n</sub>],

while the statement  $a \leftarrow \text{array} ((x_1, x_2, \dots, x_n), a)$  would additionally 'initialize all elements with  $\alpha$ '.

\*\*\*\*\*

The following is an example of a summation procedure, using what is in ALGOL known as 'Jensen's device'. The statement  $\text{sum} ('t', @i, I, u)$

has the meaning of  $\sum_{i=l}^u t$ .

```

begin new k; new I; new sum; new a; new b;
  sum ← 'formal t; formal i; formal l; formal u;
  begin i ← l;
    if l > u l+1, u) else t + sum ('t', @i,
  end';
  a ← (1, 4, 9, 16);
  b ← ((1, 4), (9, 16));

```

```

    out sum ('a[k]', @k, 1, 4);
    out sum ('a[k] X a[5-k]', @k, 1, 4);
    out sum ('sum ('b[k][l]', @l, 1, 2)', @k, 1, 2)
end

*****

begin new x; new sqrt; new elliptic; label K;
  elliptic ← 'formal a; formal b;
    if abs [a-b] ≤ 10-6 then 1.570796326/a else
    elliptic ([a+b]/2, sqrt (aXb))';
  sqrt ← 'formal a;
    begin label L; new x; x ← a/2;
      L:if abs [x2 - a] < 10-8 then x else
        begin x ← [x+a/x]/2; goto L
        end
    end';
  x ← 0.7;
K: out x; out sqrt(x); out elliptic (1,x);
  x ← x+0.1; if x ≤ 1.3 then goto K else Ω
end

```

This program contains a square-root procedure using Newton's method iteratively, and a procedure computing the elliptic integral

$$\int_0^{\frac{\pi}{2}} \frac{dt}{\sqrt{a^2 \cos^2 t + b^2 \sin^2 t}}$$

using the Gaussian method of the arithmetic-geometric mean recursively.

\*\*\*\*\*

As a final example, a permutation generator is programmed in EULER, so that the value of

perm (1, l)

is the list of all permutations of the elements of list  $l$ , i.e. a list with  
 $1 \times 2 \times 3 \times \dots \times \text{length } l$  lists :

```

begin new perm; new a; new k; label f;
  perm ← 'formal k; formal y;
    begin new rot exch; new x;
      x ← y;
      rot ← 'formal k; formal m;
        if m > length x then () else
          perm (k+1, exch (k, m, @x)) & rot (k, m+1)';
      exch ← 'formal k; formal m; formal x;
        begin new b; new t;
          t tx;
          b ← t[k]; t[k] ← t[m]; t[m] ← b; t
        end';
      if length x = k then (x) else rot (k, k)
    end';
  a ← 0;
  f: out perm (1, a); a ← a & (length a); goto f
end

```

This program generates the following lists:

- ( )
- ((0))
- ((0,1), (1,0))
- ((0,1,2), (0,2,1), (1,0,2), (1,2,0), (2,1,0), (2,0,1))
- .....

## References

1. P. Naur, ed., 'Report on the algorithmic language ALGOL 60', Comm. ACM, vol. 3, pp. 299-314; (May 1960).
2. ----, 'Revised Report on the algorithmic language ALGOL 60', Comm. ACM, vol. 6, pp. 1-17 (Jan. 1963).
3. C. Böhm, 'The CUCH as a formal and descriptive language', IFIP Working Conf., Baden, Sept. 1964.
4. P. Landin, 'The mechanical evaluation of expressions', Comp. J. vol. 6, 4 (Jan 1964).
5. P. Landin, 'A correspondence between ALGOL 60 and Church's Lambda-Notation', Comm. ACM vol. 8, 2 and 3, pp. 89-101 and 158-165.
6. A. Church, 'The calculi of lambda-conversion', Ann. of Math. Studies, vol. 6, Princeton N. J., 1941.
7. A. Curry, R. Feys and W. Craig, 'Combinatory Logic', North-Holland Pub., 1958.
8. A. van Wijngaarden, 'Generalized ALGOL', Annual Review in Automatic Programming, vol. 3, pp. 17 -26.
9. A. van Wijngaarden, 'Recursive definition of syntax and semantics', IFIP Working Conf., Baden, Sept. 1964.
10. J. van Garwick, 'The definition of programming languages by their compiler', IFIP Working Conf., Baden, Sept. 1964.
11. R. W. Floyd, 'The syntax of programming languages - a survey', IEEE Trans. on El. Comp., vol. EC-13, pp. 346-353 (Aug. 1964).
12. Y. Bar-Hillel, M. Perles and E. Shamir, 'On formal properties of simple phrase structure grammars', Zeitschrift für Phonetik, Sprachwissenschaft und Kommunikationsforschung, vol. 14, pp. 143-172; also in 'Language and Information' Addison-Wesley Pub., 1964.

13. R. W. Floyd, 'A descriptive language for symbol manipulations',  
J. ACM, vol.8, pp.579-584 (Oct. 1961).
14. R. W. Floyd, 'Syntactic analysis and operator precedence', J. ACM,  
vol. 10, pp. 316-333 (July 1963).
15. E. T. Irons, 'Structural connections in formal languages', Comm. ACM,  
vol. 7, pp. 67-71 (Feb. 1964).
16. N. Wirth, 'A generalization of ALGOL', Comm. ACM vol. 6, pp. 547-  
554 (Sept. 1963).

Acknowledgement: The authors wish to acknowledge the valuable assistance of Mr. W. M. McKeeman, who programmed the major part of the Interpreter on the Burroughs B5500 computer. His contribution includes the "Garbage Collector", a particularly subtle piece of code.

## Appendix I

The following is a listing of the syntax-processor programmed in Extended ALGOL\* for the Burroughs B5500 computer. The organization of this program is summarized as follows:

---

Input lists of non-basic symbols, basic symbols and productions

A.

B1.

C1. Build list of leftmost and rightmost symbols, cf. III B2.

C2. Establish precedence relations, cf. III B2.

B2. Find precedence functions, cf. III B5.

B3. Build tables to be used by the parsing algorithm of the EULER processor. (punch cards)

Most of the program is written in ALGOL proper. Often used extensions of ALGOL are:

1. READ and WRITE statements  
(symbol strings enclosed in < and > denote a format)
2. DEFINE declarations, being macros to be literally expanded by the ALGOL compiler.
3. STREAM procedures, being B5500 machine-code procedures, allowing the use of the B5500 character mode.

---

\* cf. Burroughs B5500 Extended ALGOL Reference Manual.

```

BEGIN COMMENT SYNTAX=PROCESSOR, NIKLAUS WIRTHDEC.1964)
  DEFINE NSY =150#; COMMENT MAX. NO. OF SYMBOLS)
  DEFINE NPH =150#; COMMENT MAX. NO. OF PRODUCTIONS)
  DEFINE UPTO = STEP 1 UNTIL #)
  DEFINE LS = "<" #, EQ = "=" #, GR = ">" #, NULL = "" #)
  FILE OUT PCH 0 (2,10); COMMENT PUNCH FILE)
  INTEGER LT; COMMENT NUMBER OF LAST NONBASIC SYMBOL)
  INTEGER K,M,N, MAX, DLON; BOOLEAN ERRORFLAG)
  ALPHA ARRAY READBUFFER(0:9), WRITEBUFFER(0:14)
  ALPHA ARRAY TEXT (0:11); COMMENT AUXILIARY TEXT ARRAY)
  ALPHA ARRAY SYTB (0:NSY); COMMENT SYMBOLTABLE)
  INTEGER ARRAY REF (0:NPR,0:5); COMMENT SYNTAX REFERENCE TABLE)
  LABEL START,EXIT)
  LABEL A,B,C,E,F,G)

STREAM PROCEURE CLEAR (D,N); VALUE NJ
  BEGIN 01 + DJ OS + 8 LIT "" ; SI t DJ DS t N WDS
  END J
STREAM PHOCEURE MARK (D,S); VALUES)
  BEGIN DI + D; SI t LOC SJ SI t SI+7; DS t CHR
  END J
BOOLEAN STREAM PROCEDURE FINIS(S);
  BEGIN TALLY +1; SI t SJ IF SC = "" THEN FINIS + TALLY
  END J
STREAM PROCEDURE EDIT (S,D,N);
  BEGIN DI + DJ SI t N; OS t 3 DEC; SI t SJ DS + 9 WDS;
  END J
STREAM PROCEDURE MOVE (S,D);
  BEGIN SI + S; 01 t D; OS + WDSJ
  END J
STREAM PROCEDURE MOVETEXT(S,D,N); VALUE NJ
  BEGIN DI t DJ SI + SJ OS + N WDS;
  END J
BOOLEAN STREAM PROCEDURE EQUAL (S,D);
  BEGIN SI t SJ DI t DJ TALLY + 1; IF 8SC = DC THEN EQUAL + TALLY;
  END J
STREAM PROCEDURE SCAN (S,DD,N);
  BEGIN LABEL A,B,C,D,E)
    SI t SJ DI t ODJ DS t 48 LIT "0"; DI + DDJ SI t SI+1)
    IF SC = " " THEN DI t DI+8)
  A) IF SC = " " THEN BEGIN SI + SI+1; GO TO A END J
    IF SC > "9" THEN GO TO DJ
    8 (IF SC = " " THEN BEGIN DS + LIT ""; GO TO E END J DS + CHR(E));
  B) IF SC ≠ " " THEN BEGIN SI + SI+1; GO TO B END J
  C) SI t SI+1; GO TO A)
  D) DI + NJ SI + SI+5; OS + 3 OCT
  END J
STREAM PROCEDURE EDITTEXT (S,D,N); VALUE NJ
  BEGIN SI + S; 01 t D; DI + DI+10; N(DI + DI+2); DS + 8 CHR)
  END J
STREAM PROCEDURE SETTEXT (A,B,C,D,E,Z);
  BEGIN 01 + Z; 01 t DI+8; SI t A; DS + 3 DEC; SI + B; DS + WDS;
    DI t DI+5; SI t C; OS + 3 DEC; DI + DI+3; SI + D; DS + 3 DEC;
    01 t DI+3; SI t E; OS + 3 DEC)

```



```

END ;
STREAM PROCEDURE PCHTX(S,D,N); VALUE N)
  BEGIN SI ← S) DI ← D;DI+DI+4;
    N(DS ← LIT ""); DS ← 8 CHR; DS ← LIT ""; DS ← LIT ",");
  END ;
PROCEDURE INPUT)
  READ(CARDFIL,10, READBUFFER[*]) [EXIT])
PROCEDURE OUTPUT)
  BEGIN WHITE (PRINFIL, 15, WRITEBUFFER[*]);
    CLEAR (WRITEBUFFER[0], 14);
  END ;
INTEGER PROCEDURE IN%(X); REAL X;
  BEGIN INTEGER II LABEL F)
    FOR I ← 0 UPTO M DO
      IF EQUAL (SYTB[I], X) THEN GO TO F J
      WRITE (<"UNDEFINED SYMBOL">); ERRORFLAG ← TRUE;
  FINX ← I
  END)

START:
  FOR N ← 0 UPTO 5 DO
    FOR M ← 0 UPTO NPR DO REP [M,N] ← 0)
      M ← N ← MAX ← 0;DN ← 0; ERRORFLAG ← FALSE;
      CLEAR (WRITEBUFFER[0],14);
      COMMENT READ LIST OF SYMBOLS, ONE SYMBOL MUST APPEAR PER CARD,
      STARTING IN COL.9 (8 CHARS. ARE SIGNIFICANT), THE LIST OF NON"
      BASIC SYMBOLS IS FOLLOWED BY AN ENDCARD ("*" IN COL.1). THEN
      FOLLOWS THE LIST OF BASIC SYMBOLS AND AGAIN AN ENDCARD J
      WRITE (<"NONBASIC SYMBOLS:">);
  A: INPUTJ
    IF FINIS (READBUFFER[0]) THEN GO TO E;
    M ← M+1;
    MOVE (READBUFFER[1], SYTB [M,;
    EDIT (READBUFFER[0], WRITEBUFFER[1], M);
    OUTPUTJ GO TO A;
  E: WRITE (</"BASIC SYMBOLS:">); LT ← M;
  F: INPUT;
    IF FINIS (READBUFFER[0]) THEN GO TO G;
    M ← M+1;
    MOVE (READBUFFER[1], SYTB[M]);
    EDIT (READBUFFER[0], WRITEBUFFER[1], M);
    OUTPUTJ GO TO FJ

  COMMENT READ THE LIST OF PRODUCTIONS, ONE PER CARD, THE LEFTPART
  IS 4 NONBASIC SYMBOL STARTING IN COL.2, NO FORMAT IS PRESCRIBED
  FOR THE RIGHT PART, ONE OR MORE BLANKS ACT 4 SSYMBOL SEPARATORS,
  IF COL.2 IS BLANK, THE SAME LEFTPART AS IN THE PREVIOUS PRODUCTION
  IS SUBSTITUTED. THE MAX. LENGTH OF A PRODUCTION IS 6 SYMBOLS;
  G: WRITE (</"SYNTAX:">);
  B: INPUT;
    IF FINIS (READBUFFER[0]) THEN GO TO C;
    MOVETEXT (READBUFFER[0], WRITEBUFFER[1], 10); OUTPUT;
    MARK (READBUFFER[9], 12); SCAN (READBUFFER[0],TEXT[0],N);
    IF N S 0 OR N > NPR OR REF[N,0] ≠ 0 THEN
      BEGIN WRITE (<"UNACCEPTABLE TAG">); ERRORFLAG ← TRUE; GO TO B

```

```

    END ;
    IF N > MAX THEN MAX ← N ;
    COMMENT THE SYNTAX IS STORED IN REF, EACH SYMBOL REPRESENTED BY
    ITS INDEX IN THE SYMBOL-TABLE ;
    FOR K ← 0 UPTO 5 DO REF [N,K] ← INX (TEXT[K]) ;
    IF REF [N,0] ≠ 0 THEN REF [N,0] ← REF [OLDN,0] ELSE.
    IF REF [N,0] > LT THEN
        BEGIN WHITE (<"ILLEGAL PRODUCTION">) ; ERRORFLAG ← TRUE END ;
    OLDN ← N ; GO TO B ;
C: IF ERRORFLAG THEN GO TO EXIT)
    N ← MAX ;
    COMMENT M IS THE LENGTH OF THE SYMBOL-TABLE, N OF THE REF-TABLE ;

BEGIN COMMENT BLOCK A ;
    INTEGER ARRAY H[0:M, 0:M] ; COMMENT PRECEDENCE MATRIX ;
    INTEGER ARRAY F, G[0:M] ; COMMENT PRECEDENCE FUNCTIONS ;
BEGIN COMMENT BLOCK B ;
    INTEGER ARRAY LINX, RINX [0:LT] ; COMMENT LEFT / RIGHT INDICES ;
    INTEGER ARRAY LEFTLIST, RIGHTLIST [0:1022] ;
BEGIN COMMENT BLOCK C1, BUILD LEFT- AND RIGHT-SYMBOL LISTS ;
    INTEGER I, J ;
    INTEGER SP, RSP ; COMMENT STACK- AND RECURSTACK-POINTERS ;
    INTEGER LP, RP ; COMMENT LEFT/RIGHT LIST POINTERS ;
    INTEGER ARRAY INSTACK [0:M] ;
    BOOLEAN ARRAY DONE, ACTIVE [0:LT] ;
    INTEGER ARRAY RECURSTACK, STACKMARK [0:LT+1] ;
    INTEGER ARRAY STACK, [0:1022] ; COMMENT HERE THE LISTS ARE BUILT ;

PROCEDURE PRINTLIST (LX, L) ; ARRAY LX, L [0] ;
    BEGIN INTEGER I, J, K ;
        FOR I ← 1 UPTO LT DO IF DONE[I] THEN
            BEGIN K ← 0 ; MOVE (SYTB[I], WRITEBUFFER[0]) ;
                FOR J ← LX[I], J+1 WHILE L[J] ≠ 0 DO
                    BEGIN MOVE (SYTB[L[J]], TEXT[K]) ; K ← K+1 ;
                        IF K ≥ 10 THEN
                            BEGIN EDITTEXT (TEXT[0], WRITEBUFFER[0], 10) ; OUTPUT ;
                                K ← 0 ;
                            END ;
                        END ;
                    END ;
                IF K > 0 THEN
                    BEGIN EDITTEXT (TEXT[0], WRITEBUFFER[0], K) ; OUTPUT END ;
                END ;
            END ;
        END ;
    END ;

PROCEDURE DUMPIT ;
    BEGIN INTEGER I, J ; WRITE ((PAGE)) ;
        WRITE (<X9, "DONE ACTIVE LINX RINX">) ;
        WRITE (<5I6>, FOR I ← 1 UPTO LT DO
            [I, DONE[I], ACTIVE[I], LINX [I], RINX[I]]) ;
        WRITE (</"STACK: se =", I3>, SP) ;
        WRITE (<I10, ":", I10I6>, FOR I ← 0 STEP 10 UNTIL SP DO
            [I, FOR J ← I UPTO I+9 DO STACK [J]]) ;
        WRITE (</"RECURSTACK:">) ;
        WRITE (<3I6>, FOR I ← 1 UPTO RSP DO
            [I, RECURSTACK[I], STACKMARK[I]]) ;

```

```

END ;
PROCEDURE RESET (X); VALUE X; INTEGER X;
BEGIN INTEGER I;
  FOR I ← X UPTO RSP DO STACKMARK [I] ← STACKMARK [X];
END ;
PROCEDURE PUTINTOSTACK (X); VALUE X; INTEGER X;
COMMENT X IS PUT INTO THE WORKSTACK, DUPLICATION IS AVOIDED!
BEGIN IF INSTACK [X] ≠ 0 THEN
  BEGIN SP ← SP+1; STACK [SP] ← X; INSTACK [X] ← SP END
ELSE IF INSTACK [X] < STACKMARK [RSP] THEN
  BEGIN SP ← SP+1; STACK [SP] ← X;
    STACK [INSTACK[X]] ← 0; INSTACK [X] ← SP;
  END ;
  IF SP > 1020 THEN
    BEGIN WRITE (</"STACK OVERFLOW"/>); DUMPIT; GO TO EXIT END ;
END ;
PROCEDURE COPYLEFTSYMBOLS (X); VALUE X; INTEGER X;
COMMENT COPY THE LIST OF LEFTSYMBOLS OF X INTO THE STACK;
BEGIN FOR X ← LINX[X], X+1 WHILE LEFTLIST[X] ≠ 0 DO
  PUTINTOSTACK (LEFTLIST[X]);
END ;
PROCEDURE COPYRIGHTSYMBOLS (X); VALUE X; INTEGER X;
COMMENT COPY THE LIST OF RIGHTSYMBOLS OF X INTO THE STACK;
BEGIN FOR X ← RINX[X], X+1 WHILE RIGHTLIST[X] ≠ 0 DO
  PUTINTOSTACK (RIGHTLIST[X]);
END ;
PROCEDURE SAVELEFTSYMBOLS (X); VALUE X; INTEGER X;
COMMENT THE LEFTSYMBOLLISTS OF ALL SYMBOLS IN THE RECURSTACK
WITH INDEX > X HAVE BEEN BUILT AND MUST NOW BE REMOVED, THEY ARE
COPIED INTO "LEFTLIST" AND THE SYMBOLS ARE MARKED "DONE" ;
BEGIN INTEGER I, J, U; LABEL L, EX;
L: IF STACKMARK [X] = STACKMARK [X+1] THEN
  BEGIN X ← X+1; IF X < RSP THEN GO TO L ELSE GO TO LX END ;
  STACKMARK [RSP+1] ← SP+1;
  FOR I ← X+1 UPTO RSP DO
    BEGIN LINX [RECURSTACK[I]] ← LP+1;
      ACTIVE [RECURSTACK[I]] ← FALSE; DONE [RECURSTACK[I]] ← TRUE;
      FOR J ← STACKMARK[I] UPTO STACKMARK[I+1]-1 DO
        IF STACK [J] ≠ 0 THEN
          BEGIN LP ← LP+1; LEFTLIST [LP] ← STACK [J];
            IF LP > 1020 THEN
              BEGIN WRITE (</"LEFTLIST OVERFLOW"/>); DUMPIT;
                PRINTLIST (LINX, LEFTLIST); GO TO EXIT
            END ;
          END ;
        LP ← LP+1; LEFTLIST [LP] ← 0;
      EX: RSP ← X;
    END ;
  END ;
PROCEDURE SAVERIGHTSYMBOLS (X); VALUE X; INTEGER X;
COMMENT ANALOG TO "SAVELEFTSYMBOLS";
BEGIN INTEGER I, J; LABEL L, EX;
L: IF STACKMARK [X] = STACKMARK [X+1] THEN
  BEGIN X ← X+1; IF X < RSP THEN GO TO L ELSE GO TO EX END ;
  STACKMARK [RSP+1] ← SP+1;

```

```

FOR I ← X+1 UPTD RSP DO
BEGIN RINX [RECURSTACK[I]] ← RP+1;
  ACTIVE [RECURSTACK[I]] ← FALSE; DONE [RECURSTACK[I]] ← TRUE;
  FOR J ← STACKMARK[I] UPTO STACKMARK[I+1]-1 DO
  IF STACK [J] ≠ 0 THEN
  BEGIN RP ← RP+1; RIGHTLIST [RP] ← STACK [J];
  IF RP > 1020 THEN
  BEGIN WRITE (</"RIGHTLIST OVERFLOW"/>); DUMPIT;
  PRINTLIST (RINX, RIGHTLIST); GO TO EXIT
  END ;
  END
END ;
RP ← RP+1; RIGHTLIST [RP] ← 0;
EX:RSP ← X;
END ;
PROCEDURE BUILDLEFTLIST (X); VALUE X; INTEGER X;
COMMENT THE LEFTLIST OF THE SYMBOL X IS BUILT BY SCANNING THE
SYNTAX FOR PRODUCTIONS WITH LEFTPART = X, THE LEFTMOST SYMBOL IN
THE RIGHTPART IS THEN INSPECTED: IF IT IS nonBASIC AND NOT MARKED
DONE, ITS LEFTLIST IS BUILT FIRST, WHILE A SYMBOL IS BEING INSPECTED
IT IS MARKED ACTIVE;
BEGIN INTEGER I, R, OWNERSP;
  ACTIVE[X] ← TRUE;
  RSP ← OWNERSP ← LINX [X] ← RSP+1;
  RECURSTACK CRSPJ ← Xi STACKMARK [RSP] ← SP+1;
  FOR I ← 1 UPTO N DO
  IF REF [I,0] = X THEN
  BEGIN IF OWNERSP < RSP THEN SAVELEFTSYMBOLS (OWNERSP);
  R ← REF [I,1]; PUTINTOSTACK (R);
  IF R ≤ LT THEN
  BEGIN IF DONE [R] THEN COPYLEFTSYMBOLS (R) ELSE
  IF ACTIVE [R] THEN RESET (LINX [R]) ELSE
  BUILDLEFTLIST (R);
  END
  END ;
END ;
PROCEDURE BUILDRIGHTLIST(X); VALUE X; INTEGER X;
COMMENT ANALOG TO "BUILDLEFTLIST";
BEGIN INTEGER I, R, OWNERSP; LABEL QQ;
  ACTIVE [X] ← TRUE;
  RSP ← OWNERSP ← RINX [X] ← RSP+1;
  RECURSTACK [RSP] ← Xi SJACKMARK [RSP] ← SP+1;
  FOR I ← 1 UPTO N DO
  IF REF [I,0] = X THEN
  BEGIN IF OWNERSP < RSP THEN SAVERIGHTSYMBOLS (OWNERSP);
  FOR R ← 2,3,4,5 00 IF REF [I,R] = 0 THEN GO TO QQ;
  QQ: R ← REF [I,R-1]; PUTINTOSTACK (R);
  IF R ≤ LT THEN
  BEGIN IF DONE [R] THEN COPYRIGHTSYMBOLS (R) ELSE
  IF ACTIVE [R] THEN RESET (RINX [R]) ELSE
  BUILDRIGHTLIST (R);
  END
  END ;
END ;
END ;

```

```

SP ← RSP ← LP ← 0;
FOR I ← 1 UPTO LT DO DONE[I] ← FALSE;
FOR I ← 1 UPTO LT DO IF NOT DONE [I] THEN
BEGIN SP ← RSP ← 0;
  FOR J ← 1 UPTO M DO INSTACK [J] ← 0;
  BUILDLEFTLIST (I); SAVELEFTSYMBOLS (0);
END ;
WRITE ([PAGE]); WRITE (<X20,"*** LEFTMOST SYMBOLS ***"/>);
PRINTLIST (LIX, LEFTLIST);
SP ← RSP ← HP ← 0;
FOR I ← 1 UPTO LT DO DONE[I] ← FALSE;
FOR I ← 1 UPTO LT DO IF NOT DONE [I] THEN
BEGIN SP ← RSP ← 0;
  FOR J ← 1 UPTO M DO INSTACK [J] ← 0;
  BUILDRIGHTLIST (I); SAVERIGHTSYMBOLS (0);
END J
WRITE ([3]); WRITE (<X20,"*** RIGHTMOST SYMBOLS ***"/>);
PRINTLIST (RIX, RIGHTLIST);
END BLOCK C1;

```

```

BEGIN COMMENT BLOCK C2, BUILD PRECEDENCE RELATIONS;
  INTEGER J,K,P,Q,R,L,T;
  LABEL NEXTPRODUCTION;
PROCEDURE ENTER (X,Y,S); VALUE X,Y,S; INTEGER X,Y,S;
  COMMENT ENTER THE RELATION S INTO POSITION [X,Y]. CHECK FOR DOUBLE-
  OCCUPATION OF THIS POSITION;
  BEGIN T ← H[X,Y]; IF T ≠ NULL AND T ≠ S THEN
    BEGIN ERRORFLAG ← TRUE;
    WRITE (<"PRECEDENCE VIOLATED BY ",2A1," FOR PAIR",2I4,
      " BY PRODUCTION",I4>, T, S, X, Y, J);
    END J
  H[X,Y] ← S;
END J
WRITE ([PAGE]);
FOR K ← 1 UPTO M DO
FOR J ← 1 UPTO M DO H[K,J] ← NULL;
FOR J ← 1 UPTO N DO
BEGIN FOR K ← 2,3,4,5 DO IF REF [J,K] ≠ 0 THEN
  BEGIN P ← REP [J,K-1]; Q ← REF [J,K];
  ENTER (P,Q,EQ);
  IF P S LT THEN
  BEGIN FOR R ← RIX[P], R+1 WHILE RIGHTLIST [R] ≠ 0 DO
    ENTER (RIGHTLIST[R],Q,GR);
    IF Q S LT THEN
    FOR L ← LIX[Q], L+1 WHILE LEFTLIST [L] ≠ 0 DO
    BEGIN ENTER (P, LEFTLIST [L], LS);
    FOR R ← RIX[P], R+1 WHILE RIGHTLIST [R] ≠ 0 DO
    ENTER (RIGHTLIST[R],LEFTLIST[L],GR)
    END
  END
  ELSE IF Q S LT THEN
  FOR L ← LIX[Q], L+1 WHILE LEFTLIST [L] ≠ 0 DO
  ENTER (P, LEFTLIST [L], LS);
END
END

```

```

ELSE GO TO NEXTPRODUCTION;
NEXTPRODUCTION: END J ;
WRITE (</X3,39I3/>, FOR J +1 UPTO M 00 J);
FOR K +1 UPTO M DO
WRITE (<I3,39(X2,A1)>>, K, FOR J + 1 UPTO M DO H(K,J));
END BLOCK C2 ;
END BLOCK B1;
IF ERRORFLAG THEN GO TO EXIT;
WRITE (</"SYNTAX IS A PRECEDENCE GRAMMAR"/>);

BEGIN COMMENT BLOCK B2. BUILD F AND G PRECEDENCE FUNCTIONS1
INTEGER I, J, K, K1, N, FMIN, GMIN, T;
PROCEDURE THRU (I,J,X); VALUE I,J,X; INTEGER I,J,X;
BEGIN WHITE (</"NO PRIORITY FUNCTIONS EXIST ",3I6>>, I,J,X);
GO TO EXIT
END ;
PROCEDURE FIXUPCOL (L,J,X); VALUE L,J,X; INTEGER L,J,X; FORWARD;
PROCEDURE FIXUPROW (I,L,X); VALUE I,L,X; INTEGER I,L,X;
BEGIN INTEGER J; F[I]+G[L]+X;
IF K1 = K THEN
BEGIN IF H[I,K] = EQ AND F[I] # G[K] THEN THRU (I,K,0) ELSE
IF H[I,K] = LS AND F[I] ≥ G[K] THEN THRU (I,K,0)
END ;
FOR J +K1 STEP -1 UNTIL 1 00
IF H[I,J] = EQ AND F[I] # G[J] THEN FIXUPCOL (I,J,0) ELSE
IF H[I,J] = LS AND F[I] ≥ G[J] THEN FIXUPCOL (I,J,1);
END ;
PROCEDURE FIXUPCOL (L, J, X); VALUE L, J, X; INTEGER L, J, X;
BEGIN INTEGER I; G[J] + F[L] + X;
IF K1 # K THEN
BEGIN IF H[K,J] = EQ AND F[K] # G[J] THEN THRU (K,J,1) ELSE
IF H[K,J] = GR AND F[K] ≤ G[J] THEN THRU (K,J,1)
END ;
FOR I + K STEP -1 UNTIL 1 DO
IF H[I,J] = EQ AND F[I] # G[J] THEN FIXUPROW (I,J,0) ELSE
IF H[I,J] = GR AND F[I] ≤ G[J] THEN FIXUPROW (I,J,1);
END ;
K1 t 0;
FOR K +1 UPTO M DO
BEGIN FMIN +1;
FOR J + 1 UPTO K1 DO
IF H(K,J) = EQ AND FMIN < G[J] THEN FMIN + G[J] ELSE
IF H(K,J) = GR AND FMIN ≤ G[J] THEN FMIN t G[J]+1;
F[K] + FMIN;
FOR J +K1 STEP -1 UNTIL 1 DO
IF H(K,J) = EQ AND FMIN > G[J] THEN FIXUPCOL (K,J,0) ELSE
IF H(K,J) = LS AND FMIN ≥ G[J] THEN FIXUPCOL (K,J,1);
K1 + K1+1; GMIN + 1;
FOR I +1 UPTO K 00
IF H(I,K) = EQ AND F[I] > GMIN THEN GMIN + F[I] ELSE
IF H(I,K) = LS AND F[I] ≥ GMIN THEN GMIN + F[I]+1;
G[K] + GMIN;
FOR I + K STEP -1 UNTIL 1 DO
IF H(I,K) = EQ AND F[I] < GMIN THEN FIXUPROW (I,K,0) ELSE:

```

```

        IF H[I,K] = GR AND F[I] ≤ GMIN THEN FIXUPROW(I,K,1))
    END K ;
END BLOCK B2 ;
WRITE ((PAGE));

BEGIN COMMENT BLOCK B3. BUILD TABLES OF PRODUCTION REFERENCES;
    INTEGER I,J,K,L;
    INTEGER ARRAY MTB [0:M]; COMMENT MASTER TABLE ;
    INTEGER ARRAY PRTB [0:M] COMMENT PRODUCTION TABLE ;
    L ← 0;
    FOR I ← 1 UPTO M DO
        BEGIN MTB[I] ← L+1;
            FOR J ← 1 UPTO N DO
                IF REF[J,1] = I THEN
                    BEGIN FOR K ← 2,3,4,5 DO
                        IF REF[J,K] ≠ 0 THEN
                            BEGIN I. ← L+1; PRTB[L] ← REF[J,K]
                                END ;
                                L ← L+1; PRTB[L] ← "J"; L ← L+1; PRTB[L] ← REF [J,0];
                            END ;
                            L ← L+1; PRTB[L] ← 0
                        END ;
    END ;

COMMENT PRINT AND PUNCH THE RESULTS;
SYMBOLTABLE, PRECEDENCE FUNCTIONS, SYNTAX REFERENCE TABLES;
WRITE (<X8,"NO,"X5,"SYMBOL",X8, "F",X5,"G",X4,"MTB"/>);
FOR I ← 1 UPTO M DO
    BEGIN SETTEXT(I,SYTB[I],F[I],G[I], MTB[I], WRITEBUFFER[0]);
        OUTPUT
    END ;
    WRITE (</"PRODUCTION TABLE:"/>);
    FOR I ← 0 STEP 10 UNTIL L DO
        WRITE (<I9,X2,10I6>, FOR I ← 0 STEP 10 UNTIL I. DO
            [I, FOR J ← I UPTO I+9 DO PRTB[J]]);
        WRITE (</"SYNTAX VERSION "A5>, TIME (0));
        WRITE (PCH, <X4,"FT+",I3,"" LT +",I4,"" LP +",I4,"" ">,LT+1,M,L);
        FOR I ← 1 STEP 6 UNTIL M DO
            BEGIN PCHTX (SYTB[I], WRITEBUFFER[0], IF M=I26 THEN 6 ELSE M=I+1);
                WRITE (PCH,10,WRITEBUFFER[*]); CLEAR (WRITEBUFFER[0],9)
            END ;
            WRITE (PCH,<X4,12(I4,"")>, FOR I ← 1 UPTO M DO F[I]);
            WRITE (PCH,<X4,12(I4,"")>, FOR I ← 1 UPTO M DO G[I]);
            WRITE (PCH,<X4,12(I4,"")>, FOR I ← 1 UPTO M DO MTB[I]);
            WRITE (PCH,<X4,12(I4,"")>, FOR I ← 1 UPTO L DO PRTB[I]);
END BLOCK B3
END BLOCK A ;

```

```

EXIT:
END,

```

## Appendix II

The following is a listing of the EULER processing system programmed in Extended ALGOL for the Burroughs B5500 computer. The organization of this program is summarized as follows :

### EULER Translator

Declarations including the procedure INSYMBOL and the code-generating procedures P1, P2, P3, FIXUP,  
Initialization of tables with data produced by the syntax-processor,  
The parsing algorithm,  
The interpretation rules (their labels correspond to their numbering in IV B)

### EULER Interpreter

Declarations including the procedures DUMP0UT (used for outputting results) and FREE (used to recover no longer used storage space when memory space becomes scarce)  
The interpretation rules for the individual instructions

The source program is punched on cards (col. 1-72) in free field format. Blank spaces are ignored, but may not occur within identifiers or word-delimiters.

An identifier is any sequence of letters and digits (starting with a letter), which is not a word-delimiter. Only the first 8 characters are significant; the remaining characters are ignored.



Appendix II (continued)

A word-delimiter is a sequence of letters corresponding to a single EULER symbol, which in the reference-language is expressed by the same sequence of underlined or boldface letters. E.g., begin → BEGIN, end → END etc. Note: ' → LQ, ' → RQ,  $\epsilon$  → TEN,  $\Omega$  → UNDEFINED.

A symbol is any BCL-character\* (or sequence of up to 5 XL-characters) enclosed between characters '"'. E.g. "\*"

An example of an EULER program is listed at the end of this Appendix.

---

\* cf. Burroughs B5500 Extended ALGOL Reference Manual.

```

BEGIN COMMENT EULER IV SYSTEM MARCH 1965 ;
INTEGER FT, LT; COMMENT INDEX OF FIRST AND LAST BASIC SYMBOL;
INTEGER LP; COMMENT LENGTH OF PRODUCTION TABLE)
ARRAY PKOGKAM C01102211
DEFINE AFIELD = [39:9] #, BFIELD = [9:30] #, CFIELD = [1:8] #;
LABEL EXIT;
FT ← 45; LT ← 119; LP ← 465; COMMENT DATA GENERATED BY SY=PR.;

```

```

BEGIN COMMENT EULER IV TRANSLATOR N.WIRTH ;
DEFINE MARK = 119 #, IDSYM = 63 #, REFSYM = 59 #, LABSYM = 62 #;
DEFINE VALSYM = 56 #, CALLSYM = 55 #, UNDEF = 0 #, NEWSYM = 60 #;
DEFINE UNARYMINUS = 116 #, NUMSYM = 68 #, BOOLSYM = 64 #;
DEFINE LISTSYM = 1028, SYMSYM = 113 #, FORSYM = 61 #;
DEFINE NAME = VCOJ #;
INTEGER I, J, K, M, N, R, T, T1, SCALE; BOOLEAN ERRORFLAG;
INTEGER BN, ON; COMMENT BLOCK- AND ORDER-NUMBER;
INTEGER NP; COMMENT NAME LIST POINTER ;
INTEGER MPJ COMMENT MARK-POINTER OF NAME-LIST;
INTEGER PRP; COMMENT PROGRAM POINTER;
INTEGER WC, CC; COMMENT INPUT POINTERS;
ALPHA ARRAY READBUFFER, WRITEBUFFER[0:14];
ALPHA ARRAY SYTB [0:LT]; COMMENT TABLE OF BASIC SYMBOLS)
INTEGER ARRAY F, G [0:LT]; COMMENT PRIORITY FUNCTIONS ;
INTEGER ARRAY MTB [0:LT]; COMMENT SYNTAX MASTER TABLE ;
INTEGER ARRAY PRTB [0:LP]; COMMENT PRODUCTION TABLE;
INTEGER ARRAY S [0:127]; COMMENT STACK ;
REAL ARRAY V [0:127]; COMMENT VALUE STACK ;
ALPHA ARRAY NL1 [0:63]; COMMENT NAME LIST ;
INTEGER ARRAY NL2, NL3, NL4 [0:63];
LABEL A0, A1, A2, A3, A4, A5, A6, A7, A8, A9;
LABEL L0, L1131, NAMEFOUND,
L1, L2, L3, L4, L5, L6, L7, L8, L9, L10, L11, L12, L13, L14, L15, L16, L17, L18, L19,
L20, L21, L22, L23, L24, L25, L26, L27, L28, L29, L30, L31, L32, L33, L34,
L35, L36, L37, L38, L39, L40, L41, L42, L43, L44, L45, L46, L47, L48, L49, L50, L51,
L52, L53, L54, L55, L56, L57, L58, L59, L60, L61, L62, L63, L64, L65, L66, L67, L68,
L69, L70, L71, L72, L73, L74, L75, L76, L77, L78, L79, L80, L81, L82, L83, L84, L85,
L86, L87, L88, L89, L90, L91, L92, L93, L94, L95, L96, L97, L98, L99, L100, L101,
L102, L103, L104, L105, L106, L107, L108, L109, L110, L111, L112, L113, L114,
L115, L116, L117, L118, L119, L120;
SWITCH BRANCH ←
L1, L2, L3, L4, L5, L6, L7, L8, L9, L10, L11, L12, L13, L14, L15, L16, L17, L18, L19,
L20, L21, L22, L23, L24, L25, L26, L27, L28, L29, L30, L31, L32, L33, L34,
L35, L36, L37, L38, L39, L40, L41, L42, L43, L44, L45, L46, L47, L48, L49, L50, L51,
L52, L53, L54, L55, L56, L57, L58, L59, L60, L61, L62, L63, L64, L65, L66, L67, L68,
L69, L70, L71, L72, L73, L74, L75, L76, L77, L78, L79, L80, L81, L82, L83, L84, L85,
L86, L87, L88, L89, L90, L91, L92, L93, L94, L95, L96, L97, L98, L99, L100, L101,
L102, L103, L104, L105, L106, L107, L108, L109, L110, L111, L112, L113, L114,
L115, L116, L117, L118, L119, L120;

```

```

STREAM PROCEURE ZERO (0);
BEGIN DI ← D; DS ← 8 LIT "0";
END ;
STREAM PROCEDURE CLEAR (0);
BEGIN DI ← 0; DS ← 8 LIT " "; SI ← D; DS ← 14 WDS
END ;

```

```

STREAM PROCEDURE MOVE (S,D);
  BEGIN SI ← SJ DI+D; DS ← WDS
  END ;
BOOLEAN STREAM PROCEDURE EQUAL (X,Y);
  BEGIN TALLY ← 1; SI ← X; DI ← Y; IF SSC = DC THEN EQUAL ← TALLY
  END J

INTEGER PROCEDURE INSYMBOL;
  COMMENT "INSYMBOL" READS THE NEXT EULER-SYMBOL FROM INPUT. 4
  STRINGS OF LETTERS AND DIGITS ARE RECOGNIZED AS IDENTIFIERS, IF
  THEY ARE NOT EQUAL TO AN EULER-IVWORD-DELIMITER.
  A CHARACTER-SEQUENCE ENCLOSED IN " IS RECOGNIZED AS A SYMBOL;
  BEGIN INTEGER I; LABEL A,B,C,D,E;
STREAM PROCEDURE TRCH (S,M,D,N); VALUE M,N;
  BEGIN SI ← SJ SI+M; DI ← D; DI ← DI+N; OS ← CHR
  END J
BOOLEAN STREAM PROCEDURE BLANK (S,N); VALUE N;
  BEGIN TALLY ← 1; SI ← SJ SI+SI+N; IF SC = " " THEN BLANK ← TALLY
  END J
STREAM PROCEDURE BLANKOUT (O);
  BEGIN DI ← O; DS ← 8 LIT " ";
  END ;
BOOLEAN STREAM PROCEDURE QUOTE (S,N); VALUE NJ
  BEGIN TALLY ← 1; SI ← SJ SI+SI+N; IF SC = "" THEN QUOTE ← TALLY
  END J
BOOLEAN STREAM PROCEDURE LETTER (S,N); VALUE NJ
  BEGIN TALLY ← 1; SI ← SJ SI+SI+N;
  IF SC = ALPHA THEN
    BEGIN IF SC < "0" THEN LETTER ← TALLY END
  END J
BOOLEAN STREAM PROCEDURE LETTERORDIGIT (S,N); VALUE NJ
  BEGIN TALLY ← 1; SI ← SJ SI+SI+N;
  IF SC = ALPHA THEN LETTERORDIGIT ← TALLY
  END J
STREAM PROCEDURE EDIT (N, S, O); VALUE NJ.
  BEGIN SI ← LOC NJ DI+O; OS ← 3 OECJ
  SI ← S; O1 ← O1 + 13; DS ← 10 WDS
  END J
PROCEDURE ADVANCE;
  COMMENT ADVANCES THE INPUT POINTER BY 1 CHARACTER POSITION;
  BEGIN IF CC = 7 THEN
    BEGIN IF WC = 8 THEN
      BEGIN READ (CARDFIL,10,READBUFFER[*])(EXIT);
      EOIT (PRP+1, READBUFFER(O), WRITEBUFFER(O));
      WRITE (PRINFIL,15, WRITEBUFFER[*]); WC ← 0
      END ELSE WC ← WC+1;
      cc ← 0;
    END
    ELSE CC ← CC+1;
  END ADVANCE J
  BLANKOUT (NAME);
  A, IF BLANK (READBUFFER [WC], CC) THEN
    BEGIN ADVANCE; GO TO A END J
  IF LETTER (READBUFFER [WC], CC) THEN
    BEGIN FOR I ← 0 STEP 1 UNTIL 7 00

```

```

        BEGIN TRCH (READBUFFER [WC], CC, NAME, I); AOVANCEJ
        IF NOT LETTERORDIGIT (READBUFFER [WC], CC) THEN GO TO C
    END J
B: AOVANCEJ
    IF LETTERORDIGIT (READBUFFER [WC], CC) THEN GO TO BJ
C:
END ELSE
IF QUOTE (READBUFFER [WC], CC) THEN
    BEGIN AOVANCEJ ZERO (NAME); NAME ← " ";
    E: TRCH (READBUFFER [WC], CC, I, 7); ADVANCE;
        IF I ≠ "" THEN
            BEGIN NAME ← I.[42:6] & NAME [18:24:24]; GO TO E END
        ELSE I ← SYMSYM GO TO O
    END ELSE
    BEGIN TRCH (REAOBUFFER [WC], CC, NAME, 0); ADVANCE
    END J
FOR I ← FT STEP 1 UNTIL LT DO
    . II: EQUAL(SYTB[I], NAME) THEN BEGIN ZERO(NAME); GO TO O END J
    I ← IDSYM)
D: INSYMBOL ← I
END INSYMBOL J

```

```

PROCEDURE P1(X); VALUE X; INTEGER X;
    BEGIN PRP ← PRP+1; PROGRAM[PRP] ← X
    END J
PROCEDURE P2(X,Y); VALUE X,Y; INTEGER X; REAL Y;
    BEGIN PRP ← PRP+1; PROGRAM[PRP] ← X; PROGRAM[PRP].BFIELD ← Y;
    END J
PROCEDURE P3(X,Y,Z); VALUE X,Y,Z; INTEGER X,Y,Z;
    BEGIN PHP ← PRP+1; PROGRAM[PRP] ← X; PROGRAM[PRP].BFIELD ← Y;
        PROGRAM[PRP].CFIELD ← Z
    END J
PROCEDURE FIXUP(I,X); VALUE I,X; INTEGER I,X;
    PROGRAM[I].BFIELD ← X;
PROCEOURE ERROR (N); VALUE NJ INTEGER NJ
    BEGIN SWITCH FORMAT ERR ←
        ("UNDECLARED IDENTIFIER"),
        ("NUMBER TOO LARGE"),
        ("LABEL IS DEFINED TWICE"),
        ("A LABEL IS NOT DECLARED"),
        ("LABEL DECLARED BUT NOT DEFINED?"),
        ("PROGRAM SYNTACTICALLY INCORRECT");
        ERRORFLAG ← TRUE;
        WRITE ([NO], ERR[N]); WRITE (<X40,"COL.",I3>, WC*8 + CC + 1)
    END ERROR J

```

```

PROCEDURE PROGRAMDUMP;
    BEGIN REAL TJ INTEGER I; LABEL LJ
    STREAM PROCEDURE NUM (N,D); VALUE NJ
    BEGIN 01 ← DJ SI ← LOC NJ OS ← 3 0 E C
    END J
    READ (<A4>, T) [L]; IF T ≠ "DUMP" THEN GO TO L;
    WRITE (< //"PROGRAM DUMP">);
    FOR I ← 1 STEP 1 UNTIL PRP 00
    BEGIN CLEAR (WRITEBUFFER[0]);

```

```

T ← PROGRAM[I]; NUM (I, WRITEBUFFER[0]);
MOVE (SYTB [T,AFIELD], WRITEBUFFER[1]);
IF T.BFIELD ≠ 0 THEN NUM (T.BFIELD, WRITEBUFFER[2]);
IF T.CFIELD ≠ 0 THEN NUM (T.CFIELD, WRITEBUFFER[3]);
IF T.AFIELD = NUMSYM THEN
  BEGIN I ← I+1; WRITE ([NO], <X14,E16.8>, PROGRAM[I]) END ;
WRITE (PRINFIL, 150 WRITEBUFFER[*])
END J

```

LIEND PROGRAMDUMP J

COMMENT INITIALISE THE SYMBOLTABLE, THE PRIORITY FUNCTIONS ANO THE PRODUCTION TABLES WITH DATA GENERATED BY THE SYNTAX-PROCESSORJ

FILL SYIB[\*] WITH 0n

```

"PROGRAM " ,"BLOCK " ,"BLOKHEAD","BLOKBODY","LABDEF " ,"STAT " ,
"STAT- " ,"EXPR " ,"EXPR=" " ,"IFCLAUSE","TRUEPART","CATENA " ,
"DISJ " ,"DISJHEAD","CONJ " ,"CONJ=" " ,"CONJHEAD","NEGATION" ,
"RELATION","CHOICE " ,"CHOICE=" " ,"SUM " ,"SUM=" " ,"TERM " ,
"TERM=" , " ,"FACTOR " ,"FACTOR=" "#" PRIMARY " ,"PROCDEF","PROCHEAD" ,
"LIST*" " ,"LISTHEAD","REFERENC","NUMBER " ,"REAL*" " ,"INTEGER*" ,
"INTEGER-"# "DIGIT " ,"LOGVAL " ,"VAR " ,"VAR=" " ,"VARDECL " ,
"FORDECL " ,"LABDECL " ,"0 " ,"1 " ,"2 " ,"3 " ,
"4 " ,"5 " ,"6 " ,"7 " ,"8 " ,"9 " ,
" ," " ," " ," " ," " ," " ,"NEW " ,
"FORMAL " ,"LABEL " ,"IDENT*" " ,"[" " ," ] " ,"BEGIN " ,
"END " ,"(" " ," ) " ,"LQ " ,"RQ " ,"GOTO " ,
"OUT " ,"+" " ,"IF " ,"THEN " ,"ELSE " ,"& " ,
"OR " ,"AND " ,"NOT " ,"=" " ,"≠ " ,"< " ,
"≤ " ,"≥ " ,"> " ,"MIN " ,"MAX " ,"+" " ,
"=" " ,"x " ,"/" " ,"%" " ,"MOD " ,"** " ,
"ABS " ,"LENGTH " "#" INTEGER " ,"REAL " "#" LOGICAL " ,"LIST " ,
"TAIL " ,"IN " ,"ISB " ,"ISN " ,"ISR " ,"ISL " ,
"ISLI " ,"ISY " ,"ISP " ,"ISU " ,"SYMBOL*" " ,"UNDEFINE" ,
"TEN " ,"#" " ,"TRUE " ,"FALSE " ,"$ " "J

```

FILL F[\*] WITH 00

```

1, 40 190 1, 20 1, 28 30 4, 1, 40 4,
58 50 50 6, 60 60 7, 7, 8, 9, 10, 11,
11, 12, 12, 13, 13, 3, 13, 3, 130 13, 13, 15,
17, 190 130 130 150 10 10 1, 190 19, 19, 190
190 19, 19, 19, 19, 190 190 16, 210 19, 13, 148
140 140 160 3, 16, 218 58 190 13, 19, 13, 12,
48 48 30 19, 19: 120 190 190 11, 80 8, 8,
80 80 80 90 90 10, 10, 11, 13, 13, 118 11, 12,
13, 13, 13, 12, 12, 13, 16, 16, 13, 13, 5J

```

FILL G[\*] WITH 00

```

10 50 6, 60 3, 10 20 30 40 50 1, 5,
50 60 60 60 7, 7, 7, 8, 90 13, 13, 10,
118 11, 12, 128 138 138 138 14, 130 18, 18, 160
178 17, 13, 13, 14, 19, 3, 19, 180 18,
18, 180 18, 180 180 180 30 15, 1, 160 130 200
40 200 140 15, 30 60 1, 148 3, 13, 3, 5,
5, 13, 5, 3, 3, 40 50 60 7, 7, 7, 7,
7, 70 7, 8, 80 10, 10, 11, 110 110 11, 12,
138 13, 13, 13, 130 138 13, 13, 13, 13, 13, 13,
130 138 130 130 160 130 130 4J

```

FILL MTB[\*] WITH 0,

1, 2, 5, 16, 258 298 30, 338 390 42, 470 48,  
558 58, 62: 68, 71, 75, 81, 84, 111, 122, 125, 136,  
1398 158, 1610 168. 1710 174, 183, 186, 198, 201, 204, 2160  
2238 2298 232, 235, 245, 256, 257, 258, 259, 2620 2650 268,  
271, 274, 277, 280, 283, 286, 289, 2908 291, 292, 2930 297,  
3018 305, 3098 315, 320, 321, 324, 325, 328, 329, 332, 3330  
3370 3410 3428 347, 348, 3498 350, 351, 3528 3568 3570 358,  
3590 360, 361, 362, 3638 3648 368, 372, 3730 374, 375, 3740.  
3770 381, 385, 389, 3930 3978 401, 405, 4080 412, 4160 420,  
424, 428, 432, 4360 440, 4438 446r 454, 4558 458, 461}

FILL PRTB[\*] WITH 0,

0, -103, 98 0, 42, 57, -115, 38 44, 57, -116, 3,  
-117, 40 0, 68 57, -118, 4, 6, 67, -119, 20 0,  
7, -110, 7, 0, 0, -112, 68 0, 770'1010 11, -111,  
7, 0, -109, 80 0, 11, 9, -104, 90 0, 00 78,  
13, -990 12, -108, 9, 0, -100, 12, 0, 138 -970 138  
0, 79, -96, 140 -988 138 0, '950 150 0, 16, -93,  
16, 0, 80, -92, 178 "940 168 -0, -90, 180 0, -83,  
19, 82, 20, -84, 19, 83, 200 -850 198 84, 20, -860  
190 85, 20, -87, 19, 868 20, -88, 19, 870 200 -89,  
19, 0, 88, 22, -80, 21, 89, 220 -810 21, -82, 20,  
0, -79, 21, 0, 90, 24, -76, 23, 910 24, -77, 238  
-78, 220 08 -73, 238 08 92, 26, -68, 258 930 26,  
-69, 25, 940 26, -70, 25, 950 26, -71, 25, -72, 248  
0r -67, 25, 0, 96, 28, -65, 27, -66, 26, 0 8 -64,  
27, 08 -46, 280 08 438 57, -350 300 88 710 -37,  
298 08 "448 28, 08 8, 550 -31, 328 80 690 -33,  
310 69, -340 310 08 '430 28, 0, -41, 280 0, -25,  
340 115, 360 -26, 348 1150 116, 36, -270 340 0, 560  
360 -230 350 -24, 350 0, 38, -210 370 "220 360 0,  
-20, 370 0, -400 280 08 -380 28, 310 -39, 280 740  
9, -105, 90 0, 640 80 65, -5, 41, 56, -6, 418  
-7, 400 08 0, 0, 0, -10, 38, 08 -11, 380 0,  
'120 38, 0, -13, 38, 0, -14, 380 0, -15, 380 0,  
-160 38, 08 -17, 38, 0, -180 38, 0, -19, 380 0 8  
08 08 0, 0, 400 -30, 330 0 8 630 '18 420 0 8  
638 '20 438 0, 63, -3, 440 0, -4, 410 58, -113,  
50 08 80 650 -48, 28, 0, 0, -114, 3 0 0, 0,  
-32, 32, 0, 0, -36, 300 0, 0, 28, -106, 90 0,  
9, -107, 9, 0, 0, 80 76, -102, 10, 0, 0, 0,  
08 08 0, 19, -91, 180 0, 0, 08 0, 0, 0,  
0, 0, 0, 340 -74, 230 0, 240 -750 238 0, 0,  
0, 08 0r 0, 280 "580 28, 08 400 9590 28, 0,  
280 -600 280, 280 -61, 28, 08 280 -620 28, 0,  
280 -63, 280 0n 280 -45, 28, 0, -490 280 0 8 40,  
-500 280 0, 408 -51, 280 0, 400 -52, 280 08 4 0 8  
-530 280 0, 400 -54, 280 0, 400 "558 280 0, 408  
'560 28, 0, 400 -57, 280 0, -42, 280 0 8 -47, 28,  
0, 36, -280 34, 1168 36, -29, 348 0, 0, -8, 39,  
0, -9, 390 0, 2, 119, -120, 1, 0}

WC + 8; CC + 7; CLEAR (WRITEBUFFER[0]); CLEAR (READBUFFER[0]);  
S[0] + MARK; ERRORFLAG + FALSE;  
I + J + BN + ON + NP + PRP + 0}

COMMENT ALGORITHM FOR SYNTACTIC ANALYSIS;  
 COMPARE THE PRIORITIES OF THE SYMBOL R AND OF THE  
 SYMBOL UN TOP OF THE STACK S. IF S[J]...S[I] CONSTITUTE A RIGHT-  
 PART OF A PRODUCTION, THEN REPLACE THIS SEQUENCE BY THE  
 CORRESPONDING LEFT-PART AND BRANCH TO THE INTERPRETATION-RULE  
 BELONGING TO THE PERFORMED PRODUCTION;

```

A0: R ← INSYMBOL;
A1: IF F[S[I]] > G[R] THEN GO TO A2;
    IF R = MARK THEN GO TO A9;
    I ← J + 1; S[I] ← R; MOVE (NAME, V[I]); GO TO A0J
A21: IF F[S[J-1]] = G[S[J]] THEN BEGIN J ← J-1; GO TO A2 END;
    M ← MTB[S[J]];
A3: IF PRB[M] = 0 THEN BEGIN ERROR(5); GO TO EXIT END;
    N ← J;
A4: N ← N+1;
    IF PRB[M] < 0 THEN GO TO A8;
    IF N ≤ I THEN GO TO A7;
A5: M ← M+1;
    IF PRB[M] ≥ 0 THEN GO TO A5;
A6: M ← M+2; GO TO A3;
A7: IF PRB[M] ≠ SCNJ THEN GO TO A5;
    M ← M+1; GO TO A4;
A8: IF N < I THEN GO TO A6;
    GO TO BRANCH[-PRB[M]];
L0: SCJJ ← PRB[M+1]; I ← J; GO TO A11;

```

COMMENT THE FOLLOWING ARE THE INTERPRETATION-RULES;

```

L1:
L2: P1(S[J]); NP ← NP+1; MOVE (V[I], NL1[NP]); ZERO (V[I]);
    NL2[NP] ← BNJ NL3[NP] ← ON ← ON+1; NL4[NP] ← S[J]; GO TO L0;
L3: NP ← NP+1; MOVE (V[I], NL1[NP]); ZERO (V[I]);
    NL2[NP] ← BNJ NL3[NP] ← NL4[NP] ← UNOEFJ GO TO L0;
L4: FOR T ← NP STEP -1 UNTIL 1 DO
    IF EQUAL (NL1[T], V[I]) THEN GO TO NAMEFOUND;
    ERROR (0); GO TO L0;
NAMEFOUND:
    IF NL4[T] = NEWSYM THEN
        P3(REFSYM, NL3[T], NL2[T]) ELSE
    IF NL4[T] = LABSYM THEN
        P3(LABSYM, NL3[T], NL2[T]) ELSE
    IF NL4[T] = FORSYM THEN
        BEGIN P3(REFSYM, NL3[T], NL2[T]); P1(VALSYM) END ELSE
        BEGIN P3(LABSYM, NL3[T], NL2[T]); NL3[T] ← PRP END;
    GO TO L0;
L5: P1(S[I]); GO TO L0;
L6: P1(VALSYM); GO TO L0;
L10:
L9: V[J] ← 0; GO TO L0J
L11:
L8: V[J] ← 1; GO TO L0J
L12: V[J] ← 2; GO TO L0J
L13: V[J] ← 3; GO TO L0J
L14: V[J] ← 4; GO TO L0;
L15: VCJJ ← 5; GO TO L0;
L16: VCJJ ← 61 GO TO L0;

```

```

L17: V[J] + 7; GO TO L0;
L18: V[J] + 8; GO TO L0;
L19: V[J] + 9; GO TO L0;
L20: SCALE + 1; GO TO L0;
L21: V[J] + V[J] * 10 + V[I]; SCALE + SCALE + 1;
      IF SCALE > 11 THEN ERROR (1); GO TO L0;
L23: V[J] + V[I] * 10 * ('SCALE) + V[J]; GO TO L0;
L26: V[J] + V[J] * 10 * V[I]; GO TO L0;
L27: V[J] + V[J] * .1 * V[I]; GO TO L0;
L28: V[J] + 10 * V[I]; GO TO L0;
L29: V[J] + .1 * V[I]; GO TO L0;
L31: V[J] + V[J] + 1; GO TO L0;
L32: V[J] + 0; GO TO L0;
L33: P2(S[I], V[J] + 1); GO TO L0;
L34: P2(S[I], V[J]); GO TO L0;
L36: BN + BN + 1; UN + 0; P2(S[J], UNDEF); V[J] + PRP;
      NP + NP + 1; ZERO (NL1[NP]); NL2[NP] + MP; MP + NP; GO TO L0;
L37: P1(S[I]); FIXUP (V[J], PRP + 1); NP + MP - 1; MP + NL2[MP];
      BN + BN - 1; GO TO L0;
L38: P1(VALSYM); GO TO L0;
L39: P1(CALLSYM); GO TO L0;
L40: P2(BOOLSYM, V[I]); GO TO L0;
L41: P1(NUMSYM); PHP + PRP + 1; PROGRAM[PRP] + V[I]; GO TO L0;
L42: P2(S[I], V[I]); GO TO L0;
L75: P1(UNARYMINUS); GO TO L0;
L92: L96: L101; L102; P2(S[I], UNDEF); V[J] + PRP; GO TO L0;
L93: L97: FIXUP (V[J], PRP + 1); GO TO L0;
L104: FIXUP (V[J], V[J] + 1); FIXUP (V[J + 1], PRP + 1); GO TO L0;
L113: FOR T + NP STEP = 1 UNTIL MP + 1 DO
      IF EQUAL (NL1[T], V[J]) THEN
        BEGIN IF NL4[T] ≠ UNDEF THEN ERROR(2);
              TI + NL3[T]; NL3[T] + PRP + 1; NL4[T] + LABSYM; ZERO (V[J]);
              L1131: IF TI ≠ UNDEF THEN
                    BEGIN T + PROGRAM[T]; BFIELD; FIXUP (T1, PRP + 1);
                          T1 + T; GO TO L1131
                    END ; GO TO L0;
        END ;
      ERROR(3); GO TO L0;
L114: BN + BN + 1; UN + 0; P1(S[I]);
      NP + NP + 1; ZERO (NL1[NP]); NL2[NP] + MP; MP + NP; GO TO L0;
L118: P1(S[I]); GO TO L0;
L119: FOR T + MP + 1 STEP 1 UNTIL NP DO IF NL4[T] ≠ UNDEF THEN ERROR(4);
      NP + MP - 1; MP + NL2[MP]; P1(S[I]); BN + BN - 1; GO TO L0;

L45: L47: L49: L50: L51: L52: L53: L54: L55: L56: L57: L58: L59: L60:
L61: L62: L63: L91: L106: L107; P1(S[J]); GO TO L0;
L65: L68: L69: L70: L71: L76: L77: L80: L81: L84: L85: L86: L87: L88:
L89: L99: L105; P1(S[J + 1]); GO TO L0;
L7: L22: L24: L25: L30: L35: L43: L44: L46: L48: L64: L66: L67: L72:
L73: L74: L78: L79: L82: L83: L90: L94: L95: L98: L100: L103: L108:
L109: L110: L111: L112: L115: L116: L117: L120; GO TO L0;

A9: P1(MARK); PROGRAMDUMP; IF ERRORFLAG THEN GO TO EXIT
END * ;

```



```

BEGIN COMMENT E U L E R IV INTERPRETER      MCKEEMAN & WIRTH ;
HEAL ARRAY S, SI, F, FI [0:1022] COMMENT STACK;
INTEGER I1, I2, LVL, FORMALCOUNT;
INTEGER SP; COMMENT TOP-STACK POINTER;
INTEGER F Pi COMMENT FREE STORAGE SPACE POINTER;
INTEGER MP; COMMENT BLOCK- OR PROCEDURE-MARK POINTER;
INTEGER PP; COMMENT PROGRAM POINTER)
LABEL ADD, SUB, MUL, DIVIDE, IDIV, REMAINDER, POWER, NEG, ABSV,
INTEGERIZE, REALL, LOGICAL, MIN, MAX, EQL, NEQ, LSS, LEQ, GEQ, GTR,
LENGTH, ISLOGICAL, ISNUMBER, ISREFERENCE, ISLABEL, ISSYMBOL,
ISLIST, ISPROCEDURE, ISUNDEFINED, LAND, LOR, LNOT, LEFTQUOTE,
RIGHTQUOTE, RIGHTPAREN, REFERENCE, PROCEDURECALL, VALUEOPERATOR,
GOTO, NEW, FORMAL, BEGINV, ENDV, STORE, THENV, ELSEV, NUMBER, LOGVAL,
LABELL, SUBSCRIPT, SEMICOLON, UNDEFIND, OUTPUT, INPUT, TAIL,
CATENATE, LISTT, SYMBOL, DONE, UNDEFINEDOPERATOR, NEXT, TRANSFER;

```

```
COMMENT SI AND FI FIELD DEFINITIONS
```

	1-4	8-17	18-27	28-37	38-47	48-97
NUMBER	TYPE					VALUE
BOOLEAN	TYPE					VALUE
SYMBOL	TYPE					VALUE
UNDEFINED	TYPE					
LIST	TYPE			LENGTH	ADDRESS	
REFERENCE	TYPE			MARK	ADDRESS	
LABEL	TYPE			MARK	ADDRESS	
PROCEDURE	TYPE		BLOCK NO.	MARK	ADDRESS	
BLOCKMARK	TYPE	DYNAMIC	BLOCK NO.	STATIC	ADDRESS	LIST

```
- DEFINE
```

```

TYPE=[1:4]#,
WCT=[28:10]#,
ADDRESS=[38:10]#,
STATIC=[28:10]#,
DYNAMIC=[8:10]#,
BLN=[18:10]#,
NSA=[18:10]#, COMMENT NEW STARTING ADDRESS FOR FREE;

```

```

UNDEFINED=0#,
NUMBERTYPE=1#,
SYMBOLTYPE=2#,
BOULEANTYPE=3#,
LABELTYPE=4#,
REFERENCETYPE=5#,
PROCEDURETYPE=6#,
LISTTYPE=7#,
BLOCKMARK=8# ;

```

```
STREAM PROCEDURE MOVE(F1, T1, W);
```

```

BEGIN LOCAL R1, R2;
SI + W; SI + SI + 6;
DI + LOC R1; DI + DI + 7; DS + CHR;
DI + LOC R2; DI + OI + 7; DS + CHR;
SI + F1; DI + T1;
R1(2(DS + 32 WDS)); DS + R2 WDS;
END;

```



```

("STACK OVERFLOW DURING GARBAGE COLLECTION"),
("ASSIGNMENT TO ANON-VARIABLE ATTEMPTED"),
("FREE STUKAGE AREA IS TOO SMALL");
WRITE ((DBL), ER[N]);
WRITE (</ "SP=", I4, " FP=", I4, " PP=", I4, " MP=", I4, " SYL=", I4/>,
      SP, FP, PP, MP, PROGRAM[PP].AFIELD);
FOR I + 1 STEP 1 UNTIL Sip DO
BEGIN WRITE((NO), <I4>, I); DUMPOUT (SI[I], S[I]) END ;
GO TO DONE
END ERROR;

```

```

PROCEDURE FREE(NEED); VALUE NEED; INTEGER NEED;
COMMENT "FREE" IS A "GARBAGE COLLECTION" PROCEDURE. IT IS CALLED
WHEN FREE STORAGE f IS USED UP, AND MORE SPACE IS NEEDED.
GARBAGE COLLECTION TAKES THE FOLLOWING STEPS:
1. ALL BLOCKMARKS, LIST DESCRIPTORS AND REFERENCES IN STACK
POINT TO VALID INFORMATION IN FREE STORAGE. LIKEWISE, ALL
LIST DESCRIPTORS AND REFERENCES THAT ARE POINTED TO ARE VALID,
ENTER INTO THE STACK ALL SUCH ENTITIES,
2. THE GARBAGE COLLECTOR MUST KNOW IN WHICH ORDER TO COLLAPSE THE
FREE STORAGE. THUS SORT THE LIST BY FREE STORAGE ADDRESS,
3. MOVE EACH BLOCK DOWN IF NECESSARY,
4. NOW THE ADDRESSES ARE WRONG--MAKE ONE MORE PASS THROUGH THE
SORTED LIST TO UPDATE ALL ADDRESSES;
BEGIN OWN INTEGER G, H, I, J; OWN REAL T;

```

```

INTEGER PKOCEDUHE FIND(W); VALUE W; REAL W;
BEGIN COMMENT BINARY SEARCH THROUGH ORDERED TABLE;
INTEGER T, N, B, KEY, K;
LABEL FOUND, BINARY;
T + G + 1; B + SP + 1;
KEY + W.ADDRESS;
BINARY: N * (B + T) DIV 2;
K + SI[N].ADDRESS;
IF K = KEY THEN GO TO FOUND;
IF K < KEY THEN B + N ELSE T + N;
GO TO BINARY;
FOUND: FIND + SI[N].NSA
END FIND;

```

```

PROCEDURE RESET(W, Z); REAL W, Z;
BEGIN INTEGER TY;
TY + W.TYPE;
IF TY = REFERENCETYPE OR TY = LISTTYPE THEN W.ADDRESS + FIND(W) ELSE
IF TY = BLOCKMARK THEN Z.ADDRESS + FIND(Z)
END RESET;

```

```

PROCEDURE VALIDATE(P); VALUE P; REAL P;
BEGIN COMMENT TREE SEARCH FOR ACTIVE LIST STORAGE;
INTEGER I, U;
G + G + 1;
IF G > 1022 THEN ERROR(12);
SI[G] + P;
U + P.ADDRESS + P.WCT - 1;
IF P.TYPE = LISTTYPE THEN FOR I + P.ADDRESS STEP 1 UNTIL U DO

```

```

    IF FI[I].TYPE = LISTTYPE OR FI[I].TYPE = REFERENCETYPE THEN
    VALIDATE(FI[I])
END VALIDATION

```

```

PROCEDURE SORT(LB, UB); VALUE LB, UB; INTEGER LB, UB;
BEGIN COMMENT BINARY SORT
    INTEGER M;
    PROCEDURE MERGE(LB, M, UB); VALUE LB, M, UB; INTEGER LB, M, UB;
    BEGIN INTEGER K, L, U, K1, K2; LABEL A, B;
        K ← UB - LB;
        MOVE(SI[LB], S[LB], K);
        L ← K + LB; U ← M; GO TO B;
    At K1 ← S[L].ADDRESS; K2 ← S[U].ADDRESS;
        IF K1 < K2 OR (K1 = K2 AND S[L].TYPE = LISTTYPE) THEN
        BEGIN SI[K] ← S[L]; L ← L + 1;
        END ELSE
        BEGIN SI[K] ← S[U]; U ← U + 1;
        END;
        K ← K + 1;
    B: IF L = M THEN ELSE IF U = UB THEN
        BEGIN K ← M - L; MOVE(S[L], SI[UB - K], K);
        END ELSE GO TO A;
    END MERGE;

```

```

    IF LB < UB THEN
    BEGIN M ← (LB + UB) DIV 2;
        SORT(LB, M); SORT(M + 1, UB); MERGE(LB, M + 1, UB + 1)
    END
END SORT)

```

```

INTEGER LLA, LLW;
G ← SP;
FOR H ← 1 STEP 1 UNTIL SP DO
    BEGIN COMMENT LOCATE ALL ACTIVE LISTS AND REFERENCES;
        IF SI[H].TYPE = LISTTYPE OR SI[H].TYPE = REFERENCETYPE THEN
        VALIDATE(SI[H]) ELSE
        IF SI[H].TYPE = BLOCKMARK THEN VALIDATE(SI[H]);
    END;
    COMMENT SORT THEM IN ORDER OF INCREASING ADDRESS;
    SORT(SP + 1, G);
    I ← 1; COMMENT COLLAPSE THE FREE STORAGE;
    FOR J ← SP + 1 STEP 1 UNTIL G DO
    IF SI[J].TYPE = LISTTYPE THEN
    BEGIN COMMENT IF G.C. OCCURS DURING "COPY" THEN WE MUST AVOID
        THE CREATION OF DOUBLE LIST ENTRIES FROM DUPLICATED DESCRIPTORS;
        IF SI[J] = SI[J + 1] THEN SI[J + 1].TYPE ← UNDEFINED;
        LLA ← SI[J].ADDRESS; LLW ← SI[J].WCT;
        IF LLA ≠ I THEN
        BEGIN
            MOVE(F[LLA], F[I], LLW);
            MOVE(FI[LLA], FI[I], LLW);
        END;
        SI[J].NSA ← I;
        I ← I + LLW;
    END ELSE SI[J].NSA ← I = LLW + SI[J].ADDRESS = LLA;

```

```

FP ← I;
COMMENT RESET ALL AFFECTED ADDRESSES)
FOR I ← 1 STEP 1 UNTIL SP DO RESET(SI[I],S[I]);
FOR I ← 1 STEP 1 UNTIL FP-1 DO RESET(FI[I],F[I]);
IF FP ← NEED > 1022 THEN ERROR(14);
END FREE ;

```

```

PROCEDURE MOVESEG(LD); REAL LD;
BEGIN COMMENT MOVE ONE LIST SEGMENT;
INTEGER W, X;
W ← LD.WCT;
IF FP + W > 1022 THEN FREE(W);
X ← LD.ADDRESS;
MOVE(F[X], F[FP], W);
MOVE(FI[X], FI[FP], W);
LD.ADDRESS ← FP;
FP ← FP + W;
END MOVE SEGMENT;

```

```

PROCEDURE COPY(LD); REAL LD;
BEGIN INTEGER I, J; COMMENT RECURSIVE LIST COPY;
MOVESEG(LD);
J ← LD.WCT - 1;
FOR I ← 0 STEP 1 UNTIL J DO
IF FI[I+LD.ADDRESS].TYPE ≠ LISTTYPE THEN COPY(FI[I+LD.ADDRESS])
END COPY;

```

```

- PROCEDURE BOOLETEST; IF SI[SP].TYPE ≠ BOOLEANTYPE THEN ERROR(1);

```

```

INTEGER PROCEDURE ROUND(X); VALUE X; REAL X; ROUND ← X;

```

```

PROCEDURE BARITH;
BEGIN IF SI[SP].TYPE ≠ NUMBERTYPE OR SI[SP-1].TYPE ≠ NUMBERTYPE THEN
ERROR(1) ELSE SP ← SP-1;
END BARITH;

```

```

PROCEDURE FETCH;
BEGIN INTEGER I;
IF SI[SP].TYPE ≠ REFERENCETYPE THEN
BEGIN I ← SI[SP].ADDRESS; SI[SP] ← F[I]; S[SP] ← F[I]; END
END FETCH ;

```

```

INTEGER PROCEDURE MARKINDEX(BL); VALUE BL; INTEGER BL;
BEGIN COMMENT MARKINDEX IS THE INDEX OF THE MARK WITH BLOCKNUMBER BL;
LABEL U1; INTEGER I;
I ← MP;
U1: IF SI[I].BLN > BL THEN
BEGIN I ← SI[I].STATIC; GO TO U1 END;
IF SI[I].BLN < BL THEN ERROR(4);
MARKINDEX ← I;
END MARKINDEX ;

```

```

PROCEDURE LEVELCHECK(X, Y); VALUE Y; INTEGER Y; REAL X;
BEGIN INTEGER T, 18 t, 8 U; T ← X.TYPE;

```

```

IF T = REFERENCETYPE OR T = LABELTYPE THEN
    BEGIN IF X.STATIC > Y THEN ERROR(5) END ELSE
IF T = PROCEDURETYPE THEN X.STATIC + Y ELSE
IF T = LISTTYPE THEN
    BEGIN L + X.ADDRESS; U + L + X.WCT - 1;
        FOR I + L STEP 1 UNTIL U DO LEVELCHECK(FI[I],Y)
    END
END LEVEL CHECK;

PROCEURE SPUPJ IF SP ≥ 1022 THEN ERROR(11) ELSE SP + SP + 1;

PRDCEURE SETIS(V); VALUE V; INTEGER VJ
BEGIN FETCH;
    SI[SP] + REAL(SI[SP].TYPE = V)J
    SI[SP].TYPE + BOOLEANTYPE;
END SET IS;

SWITCH EXECUTE +
    PROCEDURECALL, VALUEOPERATOR SEMICOLON, UNDEFINEDOPERATOR,
    REFERENCES NEWS FORMAL, LABEL, UNDEFINEDOPERATOR, LOGVAL,
    SUBSCRIPT, BEGINV, ENDV, NUMBER, RIGHTPAREN, LEFTQUOTE, RIGHTQUOTE,
    GOTO8 OUTPUT8 STORE, UNDEFINEDOPERATOR, THENV, ELSEV, CATENATES
    LOR, LAND, LNOT, EQL, NEQ, LSS, LEQ, GEQ, GTR, MIN, MAX 8
    ADD8 SUB, MUL, DIVIDE, IDIV, REMAINDER, POWER, ABSV, LENGTH,
    INTEGERIZE, REAL, LOGICAL, LIST, TAIL; INPUT,
    ISLOGICAL, ISNUMBER, ISREFERENCE, ISLABEL, ISLIST, ISSYMBOL,
    ISPROCEDURE ISUNDEFINED, SYMBOL8 UNDEFIND, UNDEFINEDOPERATOR, NEG,
    UNDEFINEDOPERATOR, UNDEFINEDOPERATOR, DONE;

    WRITE ((PAGE));
    SP + MP + PP + 0; FP + 1; LVL + 0; FT + FT + 9;

NEXT; PP + PP + 1;
TRANSFER; GO TO EXECUTE [PROGRAM[PP].AFIELD = FT];

UNDEFINEDOPERATOR;
    ERROR(0);
SEMICOLON:
    se + SP = 1; GO TO NEXT;
UNDEFIND: SPUPJ
    SI[SP].TYPE + UNDEFIND; GO TO NEXT;
NUMBER:
    PP + PP + 1; SPUPJ;
    SI[SP].TYPE + NUMBERTYPE; SCSPJ + PROGRAM[PP]; GO TO NEXT;
SYMBOL; SPUPJ
    SI[SP].TYPE + SYMBOLTYPE; SCSPJ + PROGRAM[PP].BFIELD; GO TO NEXT;
LOGVAL; SPUPJ
    SI[SP].TYPE + BOOLEANTYPE; SCSPJ + PROGRAM[PP].BFIELD;
    GO TO NEXT;
REFERENCE: SPUPJ
    SI[SP] + 0;
    SI[SP].TYPE + REFERENCETYPE;
    SI[SP].STATIC + 11 + MARKINDEX(PROGRAM[PP].CFIELD);
    SI[SP].ADDRESS + S[I], ADDRESS + PROGRAM[PP].BFIELD . 1;
    GO TO NEXT;

```

```

LABELL: SPUP;
SI[SP].TYPE ← LABELTYPE;
SI[SP].STATIC ← MARKINDEX(PROGRAM[PP],CFIELD);
SI[SP].ADDRESS ← PROGRAM[PP].BFIELD; GO TO NEXT;
CATENATE;
IF SI[SP].TYPE ≠ LISTTYPE OR SI[SP-1].TYPE ≠ LISTTYPE THEN ERROR(1);
IF SI[SP-1].ADDRESS + SI[SP-1].WCT ≠ SI[SP].ADDRESS THEN
BEGIN COMMENT MUST HAVE CONTIGUOUS LISTS;
MOVESEG(SI[SP-1]);
MOVESEG(SI[SP]);
END;
SP ← SP - 1;
SI[SP].WCT ← SI[SP].WCT + SI[SP+1].WCT;
GO TO NEXT;
LOR: BOOLTEST;
IF NOT BOOLEAN(S[SP]) THEN BEGIN SP ← SP - 1; GO TO NEXT END;
PP ← PROGRAM[PP].BFIELD; GO TO TRANSFER;
LAND: BOOLTEST;
IF BOOLEAN(S[SP]) THEN BEGIN SP ← SP - 1; GO TO NEXT END;
PP ← PROGRAM[PP].BFIELD; GO TO TRANSFER;
LNOT: BOOLTEST;
S[SP] ← REAL(NOT BOOLEAN(S[SP])); GO TO NEXT;
LSS: BARITH;
S[SP] ← REAL(S[SP] < S[SP+1]);
SI[SP].TYPE ← BUOLEANTYPE; GO TO NEXT;
LEQ: BARITH;
S[SP] ← REAL(S[SP] ≤ S[SP+1]);
SI[SP].TYPE ← BUOLEANTYPE; GO TO NEXT;
EQL: BARITH;
S[SP] ← REAL(S[SP] = S[SP+1]);
SI[SP].TYPE ← BUOLEANTYPE; GO TO NEXT;
NEQ: BARITH;
S[SP] ← REAL(S[SP] ≠ S[SP+1]);
SI[SP].TYPE ← BUOLEANTYPE; GO TO NEXT;
GEQ: BARITH;
SCSPJ ← REAL(S[SP] ≥ S[SP+1]);
SI[SP].TYPE ← BUOLEANTYPE; GO TO NEXT;
GTR: BARITH;
S[SP] ← REAL(S[SP] > S[SP+1]);
SI[SP].TYPE ← BUOLEANTYPE; GO TO NEXT;
MINI: BARITH;
IF S[SP+1] < S[SP] THEN SCSPJ ← S[SP+1]; GO TO NEXT;
MAX: BARITH;
IF S[SP+1] > SCSPJ THEN S[SP] ← S[SP+1]; GO TO NEXT;
ADD: BARITH;
SCSPJ ← S[SP] + S[SP+1]; GO TO NEXT;
SUB: BARITH;
SCSPJ ← S[SP] - S[SP+1]; GO TO NEXT;
NEG: IF SI[SP].TYPE ≠ NUMBERTYPE THEN ERROR(1);
S[SP] ← - S[SP]; GO TO NEXT;
MUL: BARITH;
S[SP] ← S[SP] × S[SP+1]; GO TO NEXT;
DIVIDE: BARITH;
IF S[SP+1] = 0 THEN ERROR(2);
S[SP] ← S[SP] / S[SP+1]; GO TO NEXT;

```

```

IDIV:  BARITH;
      IF ROUND(S[SP+1]) = 0 THEN ERROR(2);
      S[SP] ← ROUND(S[SP]) DIV ROUND(S[SP+1]); GO TO NEXT;
REMAINDER:  BARITH;
      IF S[SP+1] = 0 THEN ERROR(2);
      S[SP] ← S[SP] MOD S[SP+1]; GO TO NEXT;
POWER:  BARITH;
      S[SP] ← S[SP] * S[SP+1]; GO TO NEXT;
ABSV:  IF SI[SP].TYPE ≠ NUMBERTYPE THEN ERROR(1);
      S[SP] ← ABS(S[SP]); GO TO NEXT;
INTEGERIZE:
      IF SI[SP].TYPE > BOOLEANTYPE THEN ERROR(1);
      S[SP] ← ROUND(S[SP]); GO TO NEXT;
REALL:
      IF SI[SP].TYPE > BOOLEANTYPE THEN ERROR(1);
      SI[SP].TYPE ← NUMBERTYPE; GO TO NEXT;
LOGICAL:
      IF SI[SP].TYPE ≠ NUMBERTYPE THEN ERROR(1);
      IF S[SP] ≠ 0 OR S[SP] ≠ 1 THEN SI[SP].TYPE ← BOOLEANTYPE ELSE
      SI[SP].TYPE ← UNDEFINED;
      GO TO NEXT;
LIST:
      IF SI[SP].TYPE ≠ NUMBERTYPE THEN ERROR(1);
      I2 ← S[SP];
      IF I2 + FP > 1022 THEN FREE(I2);
      FOR I1 ← FP STEP 1 UNTIL FP + I2 - 1 DO FI[I1].TYPE ← UNDEFINED;
      SICSPJ ← TYPE ← LISTTYPE; SI[SP].WCT ← I2; SI[SP].ADDRESS ← FP;
      FP ← FP + I2; GO TO NEXT;

ISLOGICAL: SETIS(BOOLEANTYPE); GO TO NEXT;
ISNUMBER: SETIS(NUMBERTYPE); GO TO NEXT;
ISREFERENCE: SETIS(REFERENCETYPE); GO TO NEXT;
ISLABEL: SETIS(LABELTYPE); GO TO NEXT;
ISLIST: SETIS(LISTTYPE); GO TO NEXT;
ISSYMBOL: SETIS(SYMBOLTYPE); GO TO NEXT;
ISPROCEDURE: SETIS(PROCEDURETYPE); GO TO NEXT;
ISUNDEFINED: SETIS(UNDEFINED); GO TO NEXT;

TAIL:
      IF SI[SP].TYPE ≠ LISTTYPE THEN ERROR(1);
      IF SI[SP].WCT = 0 THEN ERROR(10);
      SI[SP].WCT ← SI[SP].WCT - 1;
      SI[SP].ADDRESS ← SI[SP].ADDRESS + 1; GO TO NEXT;
THENV:
      BOOLTEST; SP ← SP - 1;
      IF BOOLEAN(S[SP+1]) THEN GO TO NEXT;
      PP ← PROGRAM[PP].BFIELD; GO TO TRANSFER;
ELSEV:
      PP ← PROGRAM[PP].BFIELD; GO TO TRANSFER;
LENGTH:
      FETCH;
      IF SI[SP].TYPE ≠ LISTTYPE THEN ERROR(1);
      SI[SP].TYPE ← NUMBERTYPE; S[SP] ← SI[SP].WCT; GO TO NEXT;
GOTO:
      IF SI[SP].TYPE ≠ LABELTYPE THEN ERROR(1);

```



```

MP ← SI[SP],STATIC;
COMMENT WE MUST RETURN TO THE BLOCK WHERE THE LABEL IS DEFINED;
PP ← SI[SP],ADDRESS; SP ← MP; GO TO TRANSFER;
FORMAL:
FORMALCOUNT ← FORMALCOUNT+1;
IF FORMALCOUNT ≤ S[MP],WCT THEN GO TO NEXT ELSE GO TO NEW;
NEW:
S[MP],WCT ← S[MP],WCT + 1;
FI[FP],TYPE ← UNDEFINED;
FP ← FP + 1;
IF FP > 1022 THEN FREE(1);
GO TO NEXT;
STORE:
IF SI[SP-1],TYPE ≠ REFERENCETYPE THEN ERROR(13);
LEVELCHECK(SI[SP], SI[SP-1],STATIC);
SP ← SP - 1; COMMENT NON-DESTRUCTIVE STORE;
I1 ← SI[SP],ADDRESS;
S[SP] ← FI[I1] + S[SP+1]; SI[SP] ← FI[I1] + SI[SP+1];
COMMENT THE NON-DESTRUCTIVE STORE IS NOT APPLICABLE TO LISTS;
IF SI[SP],TYPE = LISTTYPE THEN SI[SP],TYPE ← UNDEFINED;
GO TO NEXT;
SUBSCRIPT:
IF SI[SP],TYPE ≠ NUMBERTYPE THEN ERROR(6);
SP ← SP - 1;
IF SI[SP],TYPE ≠ REFERENCETYPE THEN ERROR(7);
I1 ← SI[SP],STATIC; SI[SP] ← FI[SI[SP],ADDRESS];
IF SI[SP],TYPE ≠ LISTTYPE THEN ERROR(B);
- IF S[SP+1] < 1 OR S[SP+1] > SI[SP],WCT THEN ERROR(9);
SI[SP],ADDRESS ← SI[SP],ADDRESS + S[SP+1] . 1;
SI[SP],TYPE ← REFERENCETYPE; COMMENT MUST CREATE A REFERENCE;
SI[SP],STATIC ← I1; GO TO NEXT;
BEGINV: SPUPJ
SI[SP] ← 0;
SI[SP],TYPE ← BLOCKMARK;
SI[SP],BLN ← SI[MP],BLN + 1;
SI[SP],DYNAMIC ← MP;
SI[SP],STATIC ← MP;
S[SP],TYPE ← LISTTYPE;
S[SP],ADDRESS ← FP;
S[SP],WCT ← 0; COMMENT A NULL LIST;
MP ← SP; GO TO NEXT;
ENDV:
11 ← SI[MP],DYNAMIC;
LEVELCHECK(SI[SP], SI[MP],STATIC);
SI[MP] ← SICSPJJ S[MP] + S[SP];
SP ← MP; MP ← I1; GO TO NEXT;
LEF TQUOTE; COMMENT PROCEDURE DECLARATION;
SPUPJ
SI[SP],TYPE ← PROCEDURETYPE;
SI[SP],ADDRESS ← PP;
COMMENT THE PROCEDURE DESCRIPTOR MUST SAVE ITS OWN LEXICOGRAPHICAL
LEVEL AS WELL AS THE STACK MARKER FOR UPLEVEL ADDRESSED VARIABLES;
SI[SP],BLN ← SI[MP],BLN + 1;
SI[SP],STATIC ← MP;
PP ← PROGRAM[PP],BFIELD; GO TO TRANSFER)

```

```

RIGHTQUOTE:
  PP = SI[MP].ADDRESS;          COMMENT A PROCEDURE RETURN;
  I I + SI[MP].DYNAMIC;
  LEVELCHECK(SI[SP], SI[MP].STATIC);
  SI[MP] + SI[SP]; S[MP] + SCSPJJ
  SP + MP; MP + I; GO TO NEXT;
VALUEOPERATOR:
  IF SI[SP].TYPE = LISTTYPE THEN GO TO NEXT)
  FETCH;
  IF SI[SP].TYPE = PROCEDURETYPE THEN
  BEGIN FORMALCOUNT + 0;
    I I + SI[SP].ADDRESS;
    SI[SP].TYPE + BLOCKMARK;
    SI[SP].ADDRESS + PP;
    SI[SP].DYNAMIC + MP;
    S[SP].TYPE + LISTTYPE;
    S[SP].WCT + 0 ;
    MP + SP; PP + I;
  END ELSE IF SI[SP].TYPE = LISTTYPE - THEN COPY(SI[SP]);
  GO TO NEXT;
PROCEOURECALL:
  SP + SP - 1; FETCH;
  IF SI[SP].TYPE ≠ PROCEDURETYPE THEN ERROR(3);
  FORMALCOUNT + 0;
  I I + SI[SP].ADDRESS;
  SI[SP].TYPE + BLOCKMARK;
  SI[SP].ADDRESS + PP;
  SI[SP].DYNAMIC + MP;
  S[SP] + SI[SP+1];          COMMENT THE LIST DESC. FOR PARAMETERS;
  MP + SP; PP = I; GO TO NEXT;
RIGHTPAREN:
  I I + PROGRAM[PP].BFIELD;
  IF I I + FP > 1022 THEN FREE(I);
  SP + SP - I I + 1;
  MOVE(S[SP], F[FP], I); MOVE(SI[SP], FI[FP], I);
  SI[SP].TYPE + LISTTYPE;
  SI[SP].WCT + I;
  SI[SP].ADDRESS + FP;
  FP + FP + I; GO TO NEXT;
INPUT: SPUPJ
  READ(S[SP])[EXIT]; SI[SP].TYPE + NUMBERTYPE; GO TO NEXT;
OUTPUT:
  DUMP(OUT(SI[SP], S[SP])); GO TO NEXT;
DONE:
END INTERPRETER;

EXIT:
END .

```

```

001      BEGIN NEW FOR; NEW MAKE; NEW T; NEW AI
006      FOR + LO FORMAL CV; FORMAL LB; FORMAL STEP; FORMAL UB; FORMAL S;
013      BEGIN
014          LABEL L; LABEL K;
014          CV + LB;
020          K; IF CV S UB THEN S ELSE: GOTO L;
036          CV + CV + STEP;
047          GOTO KC
051          L; 0
052      END RQ;
057
057      MAKE + LQ FORMAL B; FORMAL X;
062      BEGIN N&W T; NEW It NEW F; NEW L;
067          4 + B; T + LIST L[1];
081          F + IF LENGTH L # 1 THEN MAKE(TAIL L; X) ELSE XI
103          FOR(0; 1, 1, L[1], LQ T[1] + F RQ) J
126          T
127      END RQ;
132
132          A + ();
136          FOR (0; 1, 1, 4, LO BEGIN A + A & (T); OUT MAKE(0A; T)ENDRQ)
165      END S

```

PROGRAM	DUMP						
001	BEGIN			030	.		
002	NEW			031	.		
003	NEW			032.	ELSE	036	
004	NEW			033	LABEL	052	003
00s	NEW			034	.		
006	@	001	001	035	GOTO		
007	LQ	056		036	;		
008	FORMAL			037	@	001	002
009	FORMAL			038	.		
010	FORMAL			039	@	001	002
011	FORMAL			040	.		
012	FORMA4			041	.		
013	BEGIN			042	@	003	002
014	@	001	002	043	.		
015				044	.		
016	@	002	002	045	+		
017	.			046	+		
018	.			047	;		
019	+			048	LABEL	021	003
020	;			049	.		
021	@	001	002	050	GOTO		
022	.			051	;		
023	.			052	(	0.00000000@+00	
024	@	004	002	054	END		
025	.			055	RQ		
026	.			056	+		
027	S			057	;		
028	THEN	033		058	@	00a	001
029	@	005	002	059	LQ	131	

060	FORMAL			120	Q	003	003
061	FORMAL			121	.		
062	BEGIN			122	+		
063	NEW			123	RQ		
064	NEW			124	)	005	
065	NEW			125	,		
066	NEW			126	;		
067	Q	004	003	127	Q	001	003
068	Q	001	002	128	.		
069	.			129	END		
070	.			130	RQ		
071	←			131	←		
072	;			132	;		
073	+	001	003	133	Q	004	001
074	+	004	003	134	)		
075	(	1.000000000E+00		135	←		
077	)			136	;		
078	.			137	Q	001	001
079	LIST			138	Q	003	001
080	←			139	(	1.000000000E+00	
081	;			141	(	1.000000000E+00	
082	+	003	003	143	(	4.000000000E+00	
083	+	004	003	145	LQ	165	
084	⊗ ⊗ ⊗ ⊗ ⊗ ⊗			146	BEGIN		
083	(	1.000000000E+00		147	Q	004	001
087	⊗			148	Q	004	001
088	⊗ ⊗ ⊗	099		149	.		
089	⊗	002	001	150	⊗	003	001
090	⊗	004	003	151	.		
091	.			152	)	001	
092	TAIL			153	&		
093	Q	002	002	154	←		
094	.			155	;		
095	.			156	⊗	002	001
096	)	002		157	⊗	004	001
097	,			158	⊗	003	001
098	ELSE	102		159	.		
099	Q	002	002	160	)	002	
100	.			161	,		
101	.			162	OUT		
102	←			163	END		
103	;			164	RQ		
104	Q	001	001	165	)	005	
105	Q	002	003	166	,		
106	(	1.000000000E+00		167	END		
108	(	1.000000000E+00		168	S		
110	Q	004	003				
111	(	1.000000000E+00					
113	)						
114	.						
115	LQ	124					
116	⊗	001	003				
117	Q	002	003				
118	.						
119	)						

(	LIST	24			NUMB&H		4
)	NUMBER		1		NUMB&R		4
(	LIST	61		...)	LIST	382	
.(	LIST	62		...)	NUMBER		4
)	NUMB&R		2		NUMBER		4
..)	NUMBER		2		NUMBER		a
)					NUMB&R		a
(	LIST	142		...)			
.(	LIST	143		..)			
..(	LIST	145		.)			
)	NUMBER		3	)			
..)	NUMBER		3				
..(	NUMBER		3				
..)	LIST	148					
..(	NUMB&R		3				
..)	NUMB&R		3				
..(	NUMB&R		3				
..)							
.)							
)							
(	LIST	353					
.(	LIST	354					
..(	LIST	356					
...)	LIST	359					
..)	NUMB&R		4				
..(	NUMB&R		4				
..)	NUMBER		4				
..(	NUMBER		4				
..)	NUMBER		4				
..(	LIST	363					
..)	NUMB&R		4				
..(	NUMBER		4				
..)	NUMB&R		4				
..(	NUMB&R		4				
..)	LIST	367					
..(	NUMBER		4				
..)	NUMBER		4				
..(	NUMBER		a				
..)	NUMBER		4				
..(	LIST	371					
..)	LIST	374					
..(	NUMBER		4				
..)	NUMBER		4				
..(	NUMBER		4				
..)	NUMBER		4				
..(	LIST	378					
..)	NUMBER		4				
..(	NUMBER		4				













-

.